







































































































































































































## Fusing element removal (continued)

### Figure 4-29 Releasing the Fusing Element Cable Connection, Left Side

The Fusing Element has electronic cable connections on both the left and right ends, outside the printer.

- 2 Disconnect the small cable on the left by gently pulling the connection apart.

## Fusing element removal (continued)

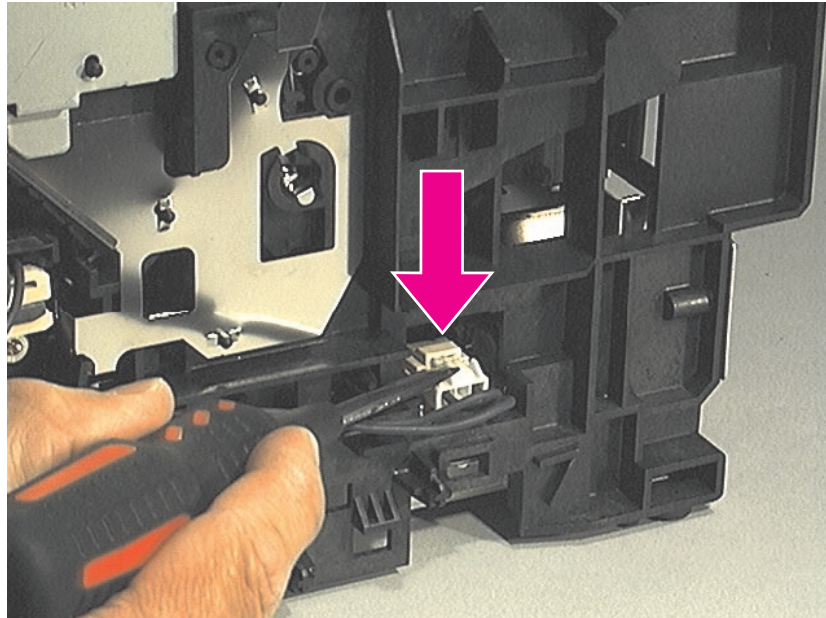
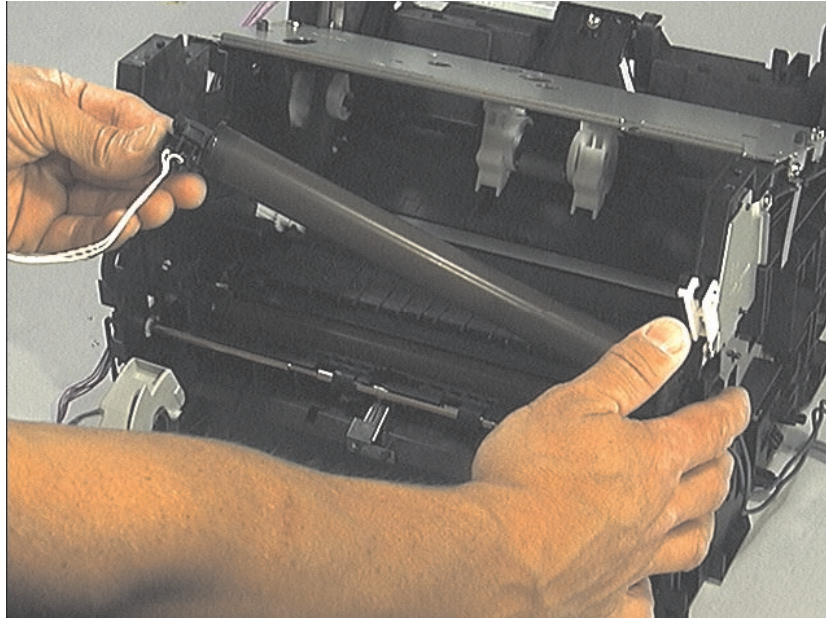

**Figure 4-30 Releasing the Fusing Element Cable Connection, Right Side**

The larger double cable on the right end is held in place by a plastic snap.

- 3** Press down on the top of the plastic snap with a flat-head screwdriver.
- 4** Unwind the cable from the cable guides along the side of the printer.

## Fusing element removal (continued)



**Figure 4-31 Removing the Fusing Element**

- 5 After the two cables are disconnected from the right and left sides of the printer, lift the element gently out of the printer.

## Gear train motor and solenoid removal

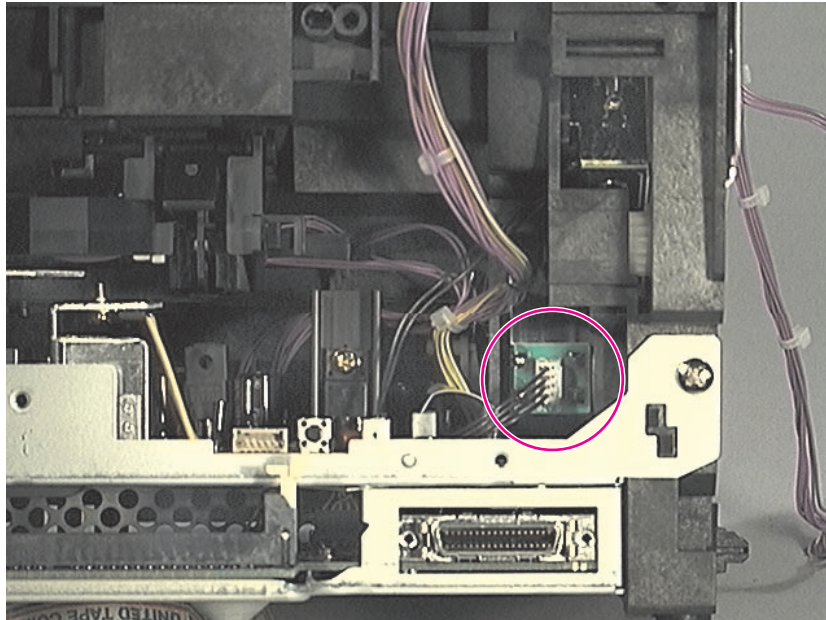

**Figure 4-32 Motor Cable Connection to Gear Train Cover**

Prior to this step: Remove pods, memory card (if applicable), scanner, back cover, printer door, paper guides, and front cover.

The Gear Train, located behind the metal plate (Gear Train Cover) on the left side of the printer, must be removed to access the Pressure Roller.

- 1 Disconnect the motor cable connection at the back of the printer.

## Gear train motor and solenoid removal (continued)

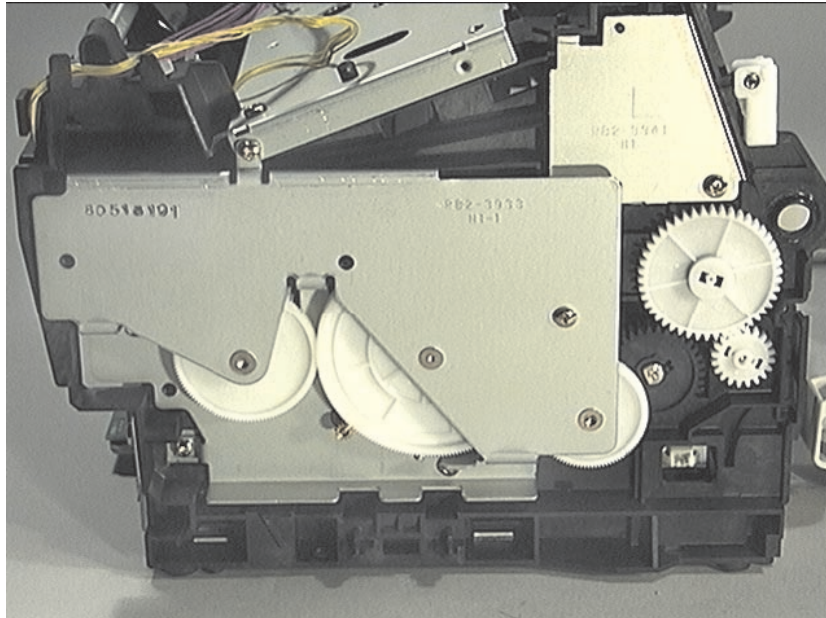

**Figure 4-33** Gear Train Cover

- 2 Remove the four screws securing the metal plate over the Gear Train and very gently release it.

## Gear train motor and solenoid removal (continued)

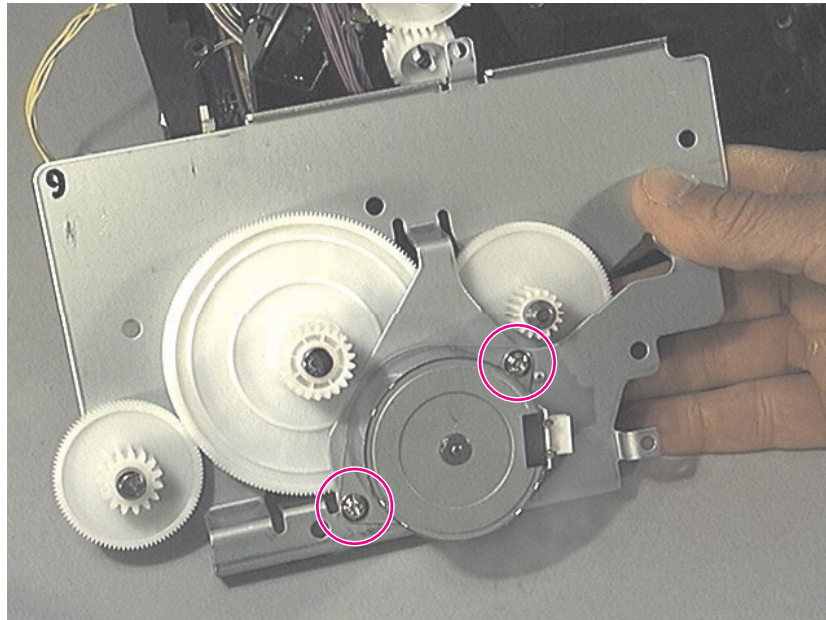

**Figure 4-34** Removing the Gear Train Motor

---

**Note**

---

Some gears are not all held in place and may come apart during removal.

- 3 Remove the two screws holding the Gear Motor to the Gear Plate Cover.
- 4 Pull the Gear Motor out of the Gear Plate Cover.

## Solenoid removal

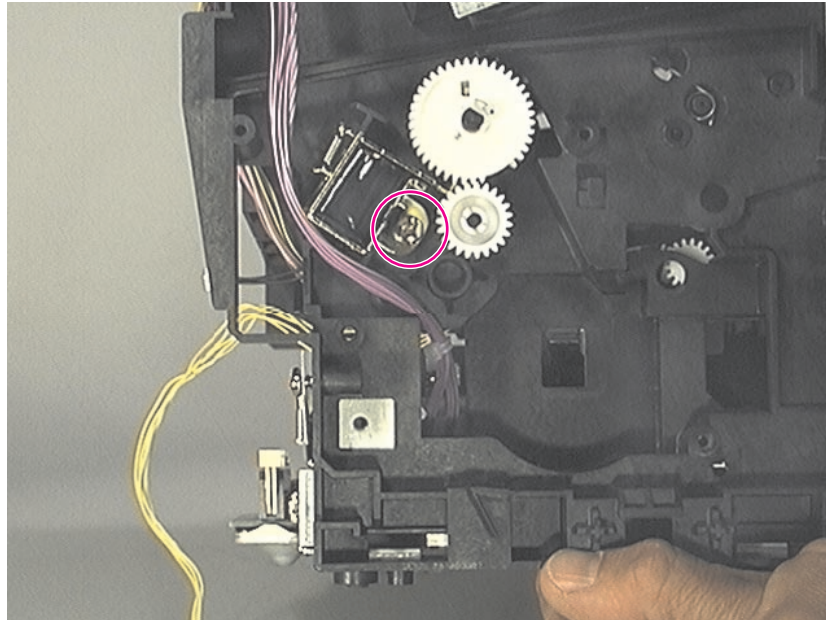

**Figure 4-35 Solenoid removal**

- 5 Remove the single screw securing the solenoid to the printer chassis.
- 6 Release the solenoid.

---

**Note**

During reassembly, rotate the clutch so that the flat spot on the clutch allows the feed roller (gear) to turn freely.

---

## Pressure roller removal

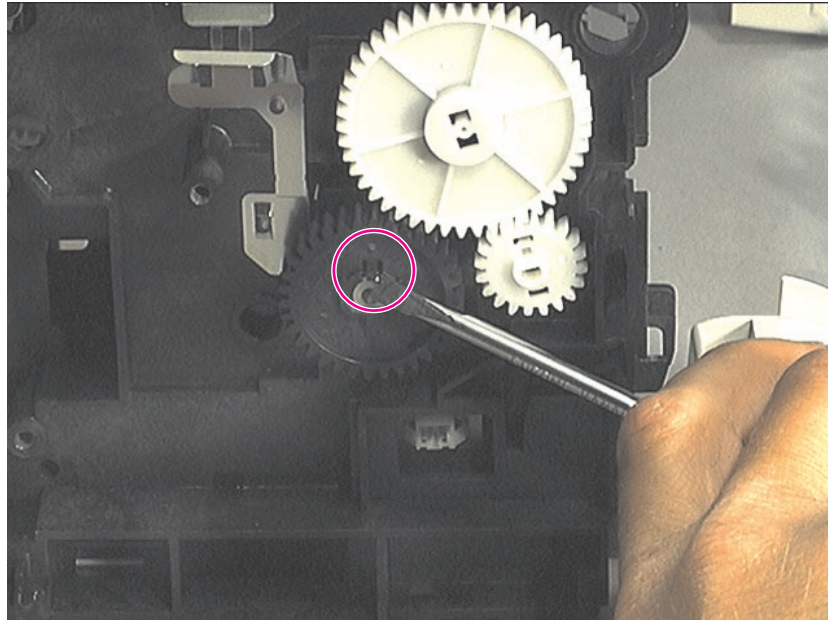

**Figure 4-36 Removing the Pressure Roller (continued on next page)**

Prior to this step: Remove the scanner, pods, printer door, memory card (if applicable), paper guide, front cover back cover, output roller, delivery assembly, fuser assembly, and gear train.

- 1 Using a flat-head screwdriver, remove the gear from the end of the Pressure Roller by gently prying the small plastic tab up from the slot in the end of the roller axles.
- 2 Slide the gear off the end of the roller.



## Pressure roller removal

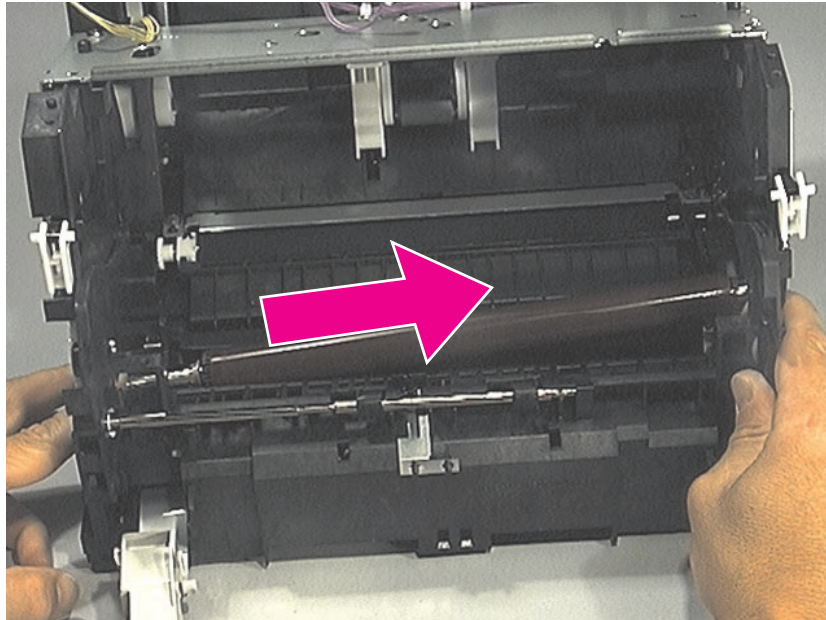

**Figure 4-37** Removing the Pressure Roller

---

**CAUTION**

This Pressure Roller is covered with light contact grease. Do not get it on your clothes. See Chapter 6, "Parts and diagrams," for information about ordering pressure roller grease.

---

**Note**

The half bushing on the right of the assembly or the full bushing on the left end of the assembly are not connected to the printer chassis and may come loose during removal.

- 3** Loosen the two screws in the fusing guide.
- 4** Lift the right end of the Pressure Roller out of the half bushing and slowly move the roller to the right, pulling the left end of the roller axle out of the opening on the left side of the printer.

## Transfer roller removal

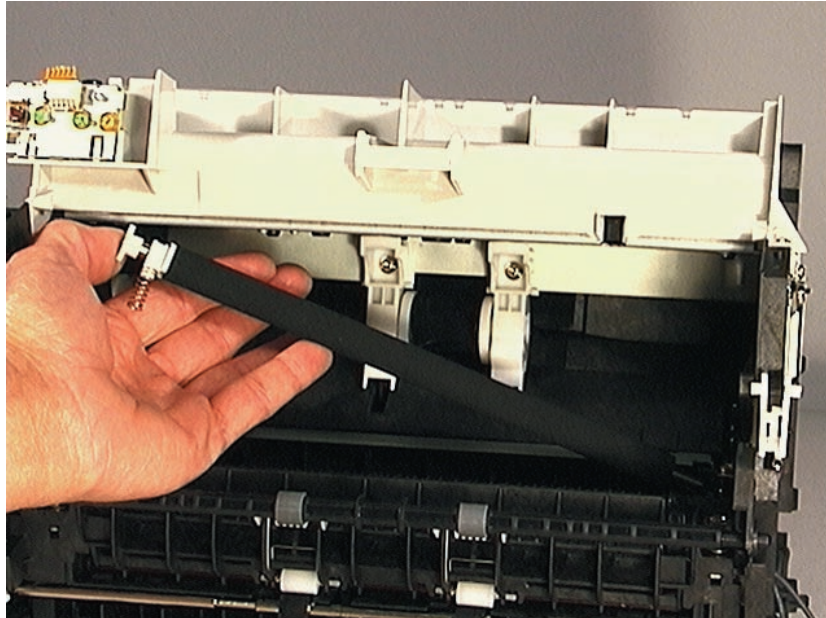

---

**Note**

The Transfer Roller can be removed without disassembling any other printer parts.

---

**CAUTION**

Do not touch the black portion of the Transfer Roller.

---

**Note**

A grounding spring is attached to the bottom of the left end of the Transfer Roller. This spring may come loose during assembly or removal.

- 1 Using needle nose pliers, release the Transfer Roller by gently squeezing the small plastic snaps on the left end of the roller.
- 2 Lift the Transfer Roller up and out.

## Pickup roller removal

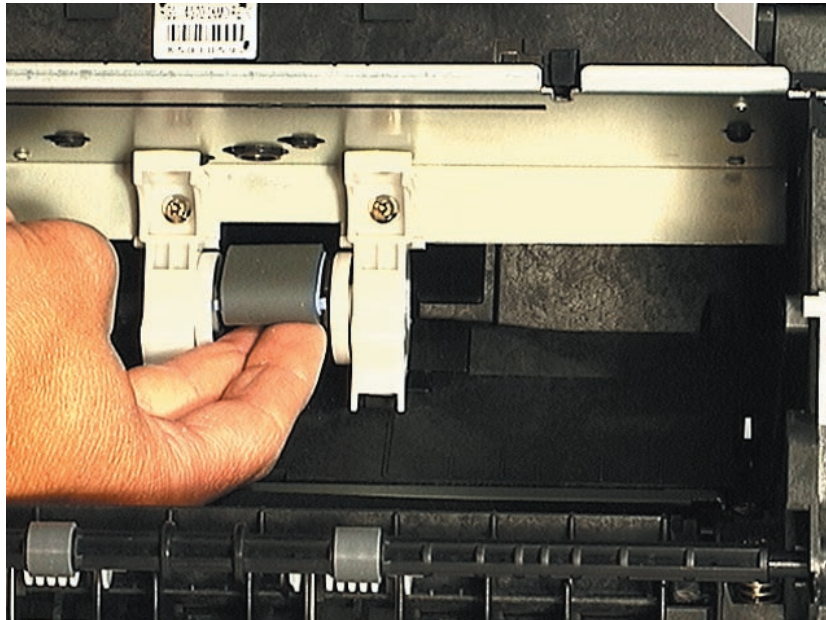
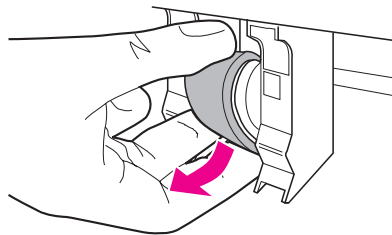
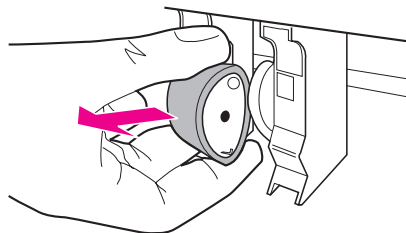

Figure 4-38 Changing the Pickup Roller



- 1 Rotate the bottom of the pickup roller towards the front of the printer.



- 2 Gently pull the pickup roller straight out.

## Paper pick-up assembly removal

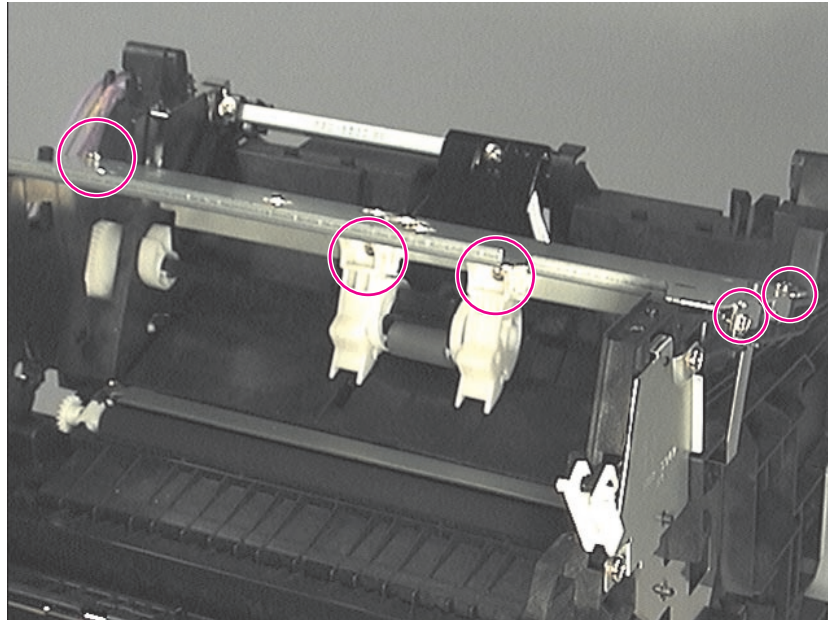
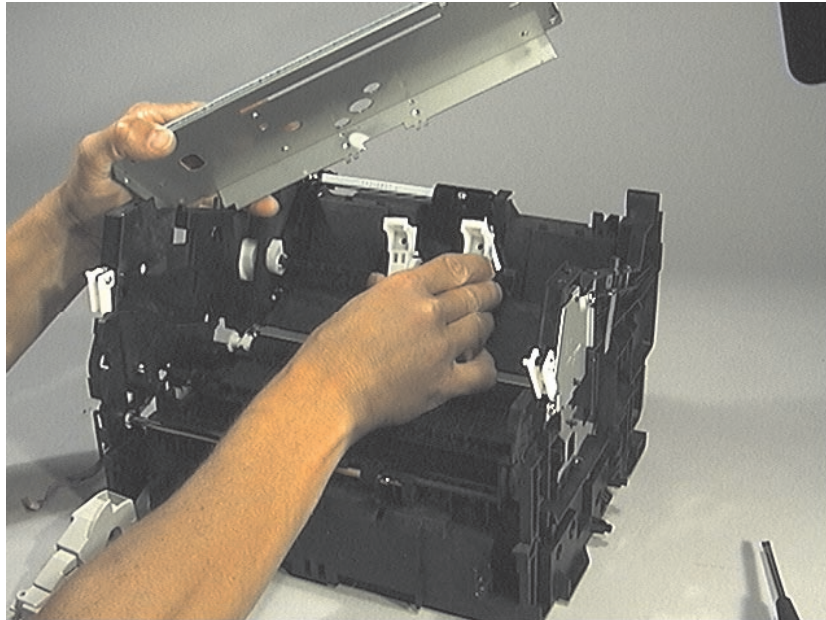

**Figure 4-39** Accessing the Paper Pick-up Assembly Area.

Prior to this step: Remove memory card (if applicable), scanner, pods, front door, front cover, back cover, paper guide, top cover, and disconnect laser/scanner.

- 1** Remove the screw attached to a bracket at the right end of the cover plate (callout 1).
- 2** Remove the two top screws attached to the right and left of the plate (callouts 2 and 3).
- 3** Remove the two screws located underneath the plate, securing it to the Paper Pick-up Assembly (callouts 4 and 5).

## Paper pick-up assembly removal (continued)



**Figure 4-40** Removing the Paper Pick-up Assembly Cover

---

**Note**

---

The Pickup Assembly is in several pieces; these pieces should be kept together.

- 4 Lift the metal plate clear of the printer.
- 5 Remove the Paper Pickup Assembly.

## Kick plate removal

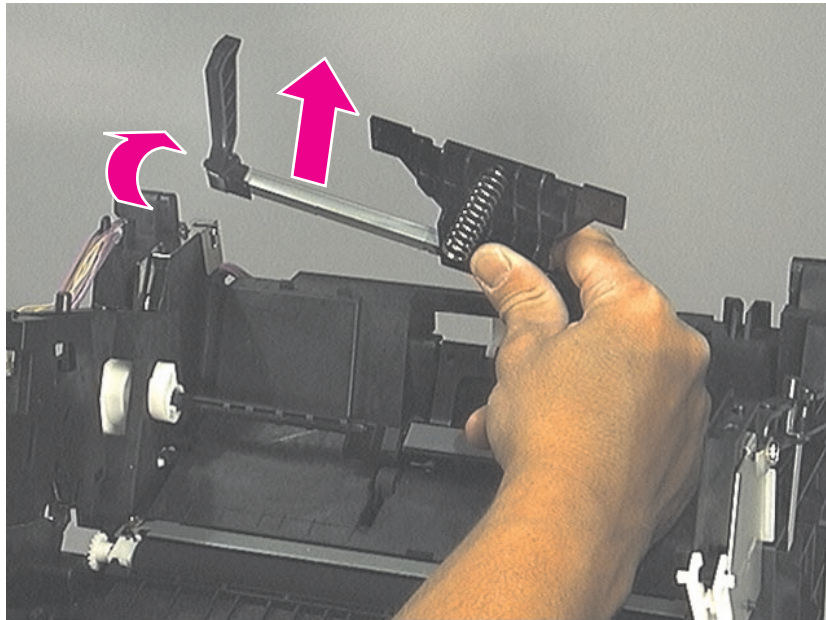
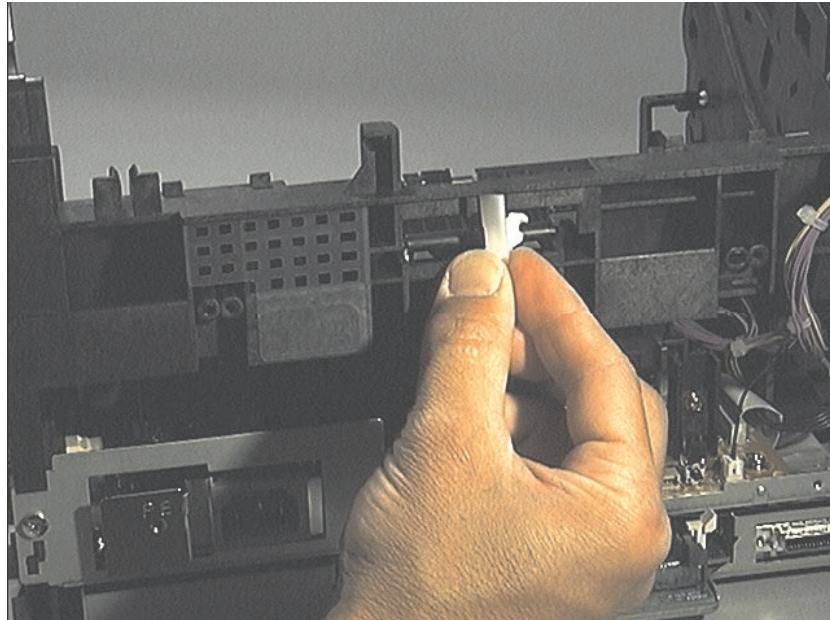

**Figure 4-41 Removing the Kick Plate**

Prior to this step: Remove memory card (if applicable), scanner, pods, front door, front cover, back cover, paper guide, top cover, and disconnect laser/scanner.

- 1 Rotate the cam to free the Kick Plate.
- 2 Rotate the Kick Plate arm up approximately 45 degrees and lift the left end up and out of the collar shaft securing it.

## Separation pad removal

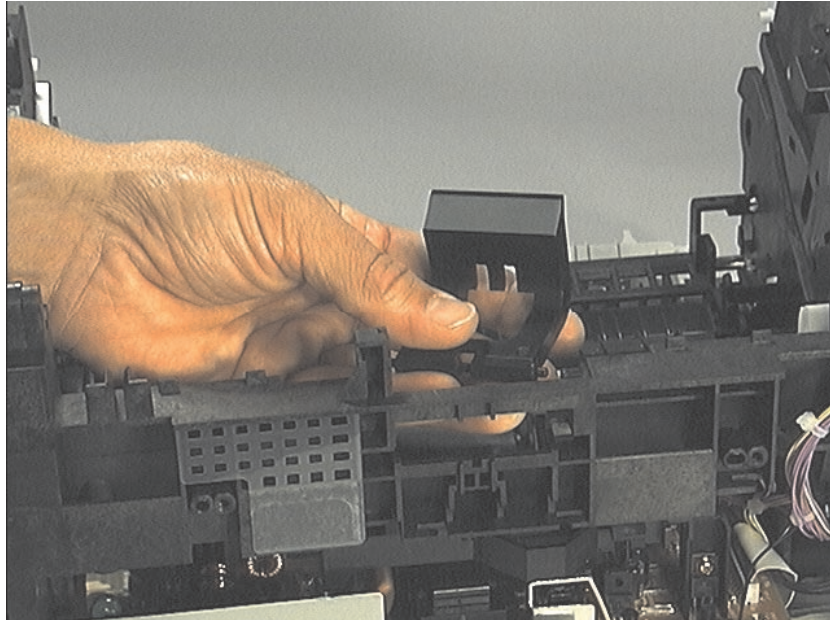

**Figure 4-42 Snap Holding Separation Pad**

Prior to this step: Remove memory card (if applicable), scanner, pods, front door, front cover, back cover, paper guide, top cover, kick plate, and disconnect laser/scanner.

- 1 Remove the plastic snap on the opposite side of the printer from the Kick Plate.

## Separation pad removal (continued)



**Figure 4-43** Removing the Separation Pad

- 2 Slide the Separation Pad out through the brackets securing it.



# Bottom assemblies

## Formatter pan removal

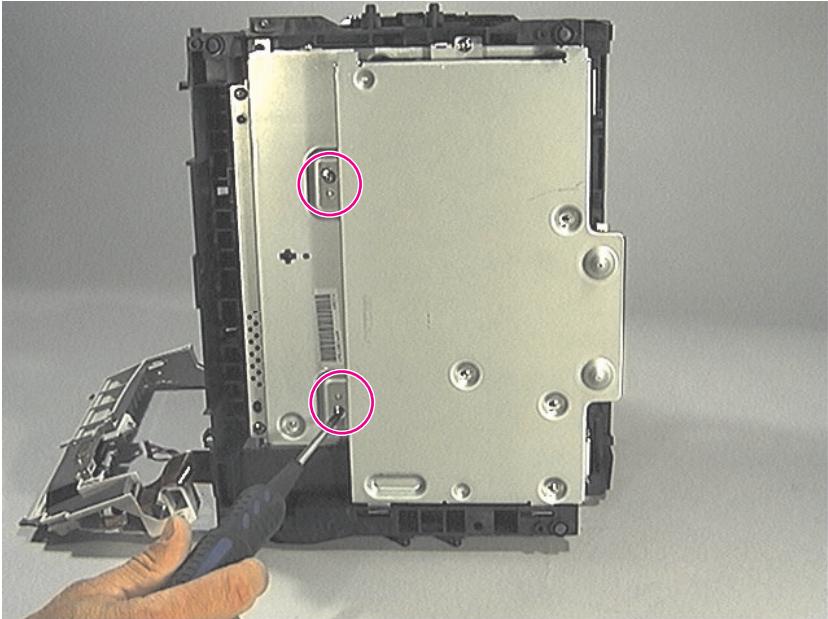
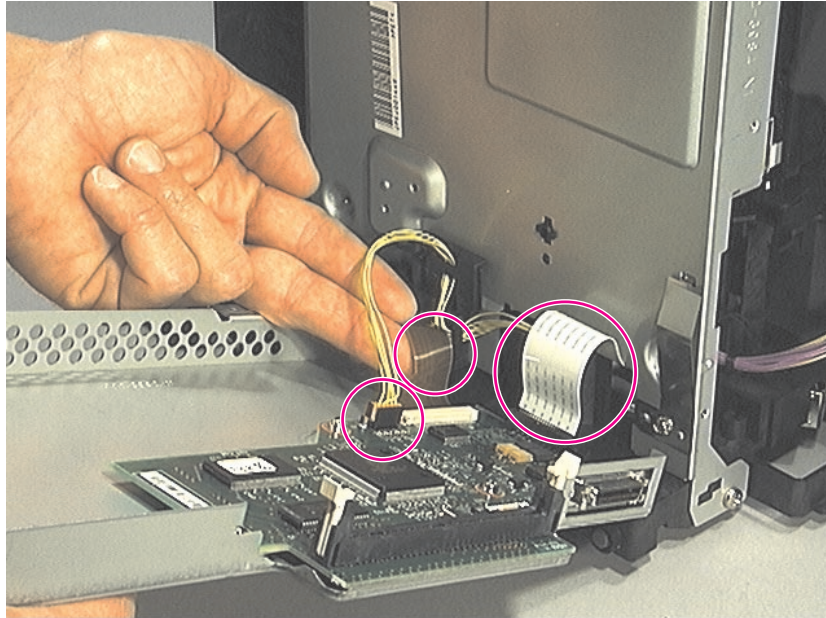

Figure 4-44 The Formatter Pan (continued on next page)

- 1 Remove the three screws holding the Formatter Pan to the bottom of the printer chassis. The third screw is located on a bracket at the end of the pan.

## Formatter pan removal (continued)



**Figure 4-45** Removing the Formatter Pan (continued)

---

**Note**

---

Be careful not to damage or break the electronic cables and connections underneath the formatter pan.

- 2 Slowly rotate the Formatter Pan away from the chassis.
- 3 Unplug the small connector cable and two flat flexible cables.
- 4 Slide the Formatter Pan free of the metal brackets.
- 5 To remove the Formatter from the Formatter Pan, remove the four screws securing the Formatter.

---

**Note**

---

During reassembly, make sure the pan is re-seated in the brackets.

## Document scanner cable removal

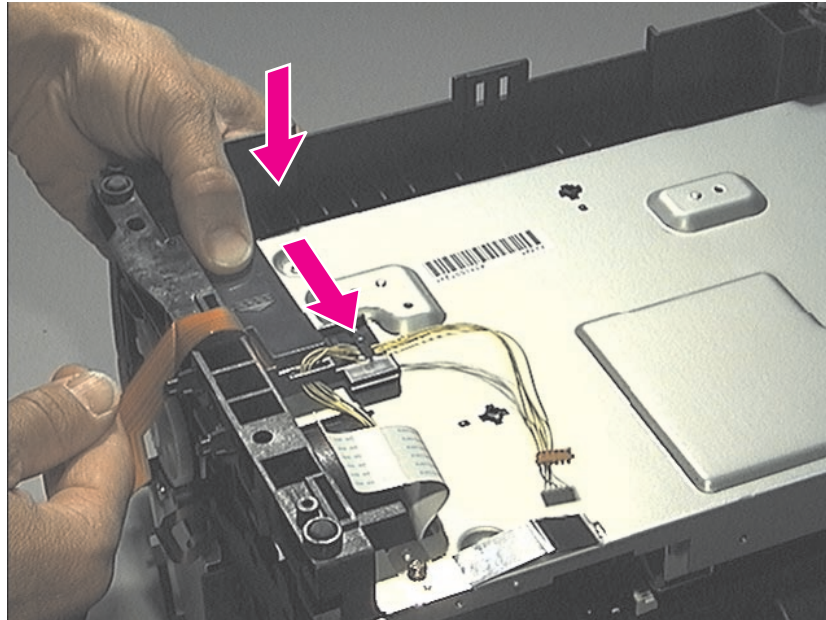
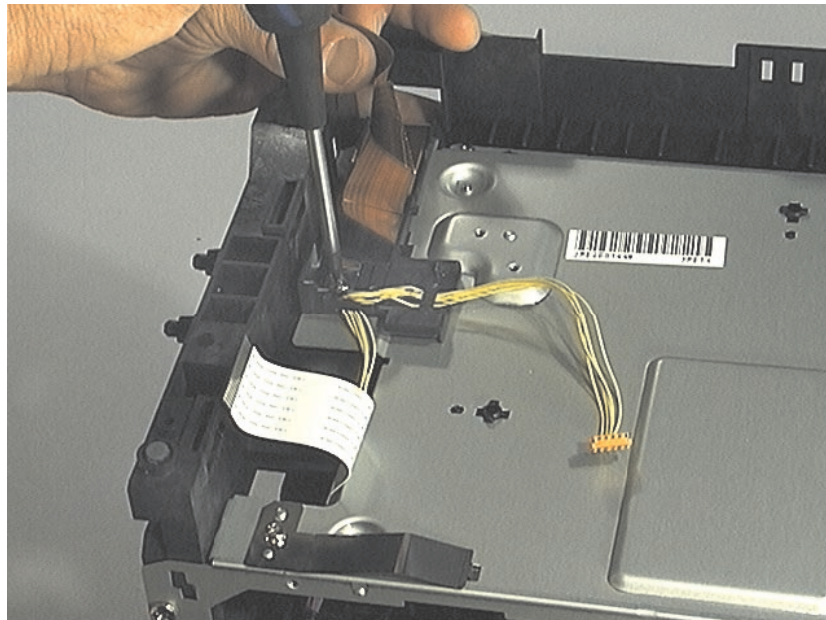

**Figure 4-46** Removing the ECU Pan Cable Cover

Prior to this step: Remove scanner, pods, doors, back cover, front cover, and formatter.

- 1 Push down and back on the plastic cable cover on the bottom of the ECU Pan (the cable cover is marked with raised directional arrows).
- 2 Remove the cover, exposing the cable underneath.

## Document scanner cable removal (continued)



**Figure 4-47** Removing ECU Pan Flat Flexible Cable

- 3 Remove the screw from the cable guide.
- 4 Slide the flat cable and attached grounding slip out from under the holding tabs.
- 5 Carefully slide the cable and grounding slip out through the opening in the printer chassis.

## Removing the hinge mechanism

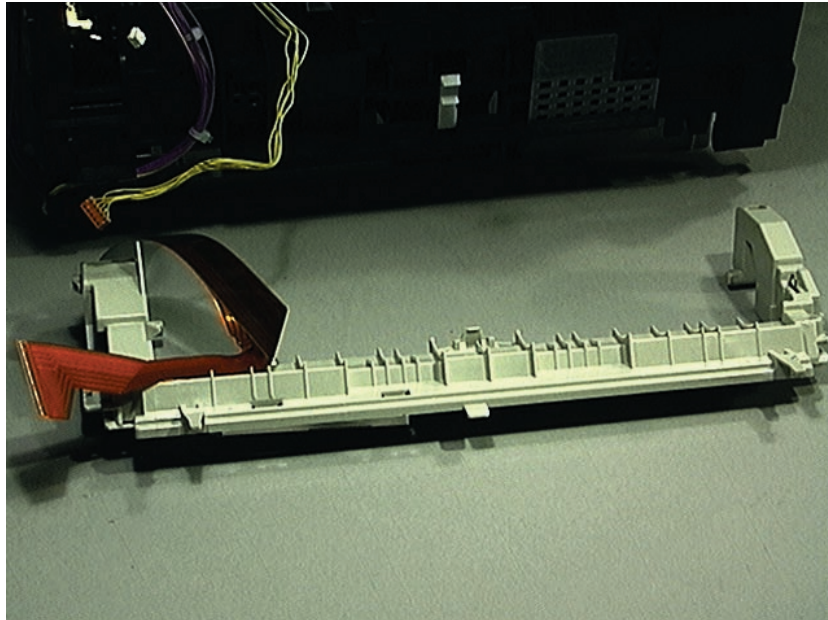

**Figure 4-48 Hinge Mechanism Removed**

- 6 Slide the hinge mechanism and attached cables out of the chassis.

## ECU pan removal

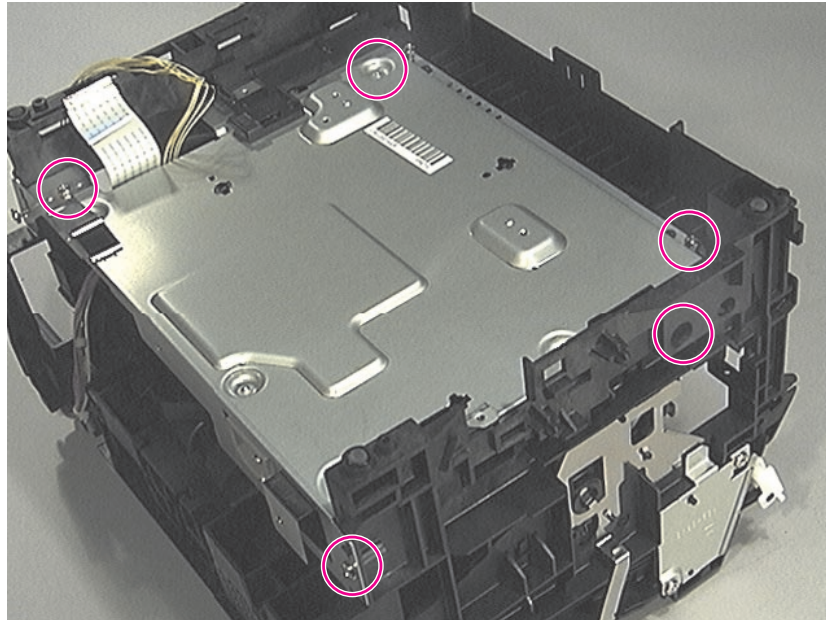

**Figure 4-49** ECU Pan

Prior to this step: Remove scanner, pods, doors, back cover, front cover, formatter, and disconnect ECU cable.

---

**Note**

---

If fuser cables are connected, disconnect them before removing the ECU pan.

- 1 Remove the two screws fastened to the brackets on the sides of the pan.
- 2 Remove the two screws accessed through openings in the side of the black plastic printer chassis.
- 3 Disconnect the small solenoid connection from the back of the ECU.

## ECU pan removal (continued)

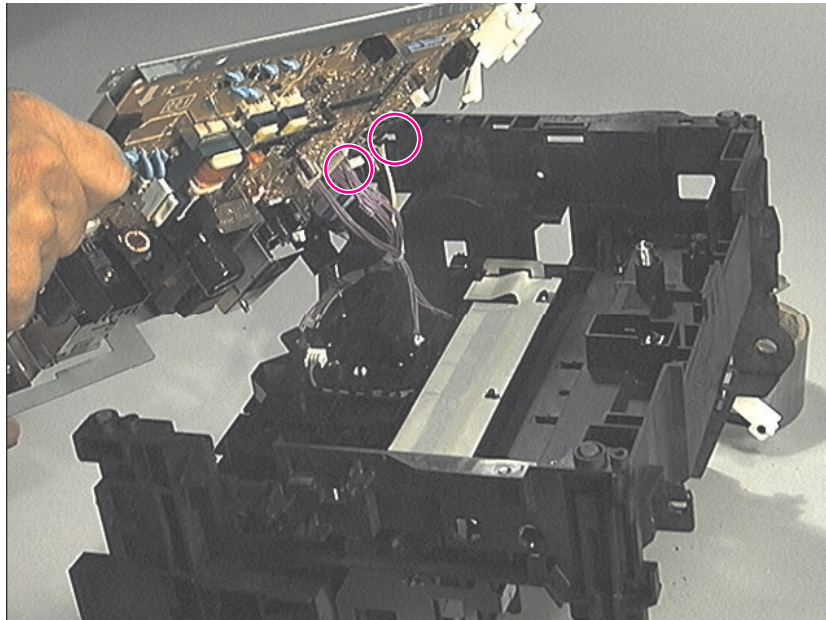

**Figure 4-50** Removing the ECU Pan (Continued on Next Page)

- 4 Slowly lift the ECU plate away from the printer chassis.

---

### CAUTION

---

Be very careful not to damage or break the connectors underneath the ECU plate as you lift it from the printer chassis.

- 5 Reach between the plate and the chassis and unwind the cables from their cable guides until there is enough slack in the cables to allow access to the bottom of the ECU plate.
- 6 Unwind and disconnect all cables until the ECU board is separated from the chassis.

---

### Note

---

The entire ECU Board can be replaced as a single unit (cables do not ship with the replacement board; if cables are damaged during removal, you will need to purchase new ones).

## Paper feed assembly removal

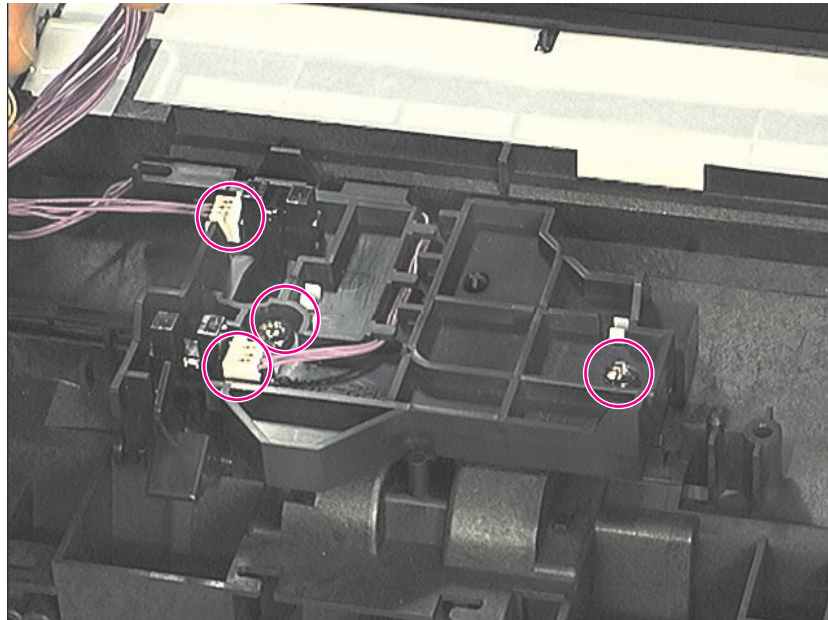

**Figure 4-51 Removing the Paper Feed Assembly (continued on next page)**

Prior to this step: Remove scanner, pods, doors, back cover, front cover, formatter, and disconnect ECU cable, and remove ECU pan.

- 1 Disconnect the two cable connections.
- 2 Partially unwind the cables from their cable guides.
- 3 Remove the two screws securing the assembly to the printer chassis.
- 4 Lift paper feed frame away from chassis, being careful not to damage sensor flags.

---

**Note**

---

Reassembly note: Be sure to seat the tab into the frame.



## Paper feed assembly removal (continued)

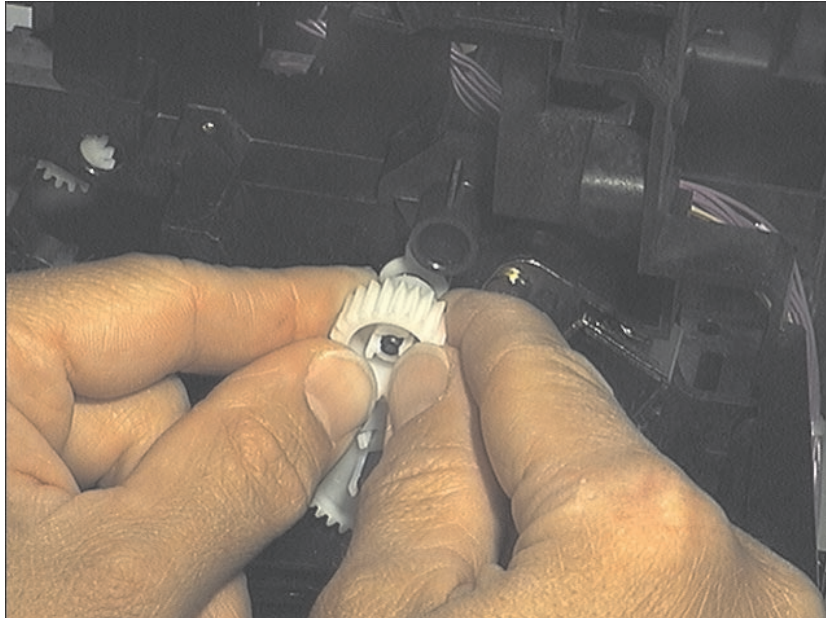

**Figure 4-52** Removing the Paper Feed Assembly (continued)

- 5 Release the snap catches inside the gear on the left end of the Paper Feed Roller Shaft.

## Paper feed assembly removal (continued)

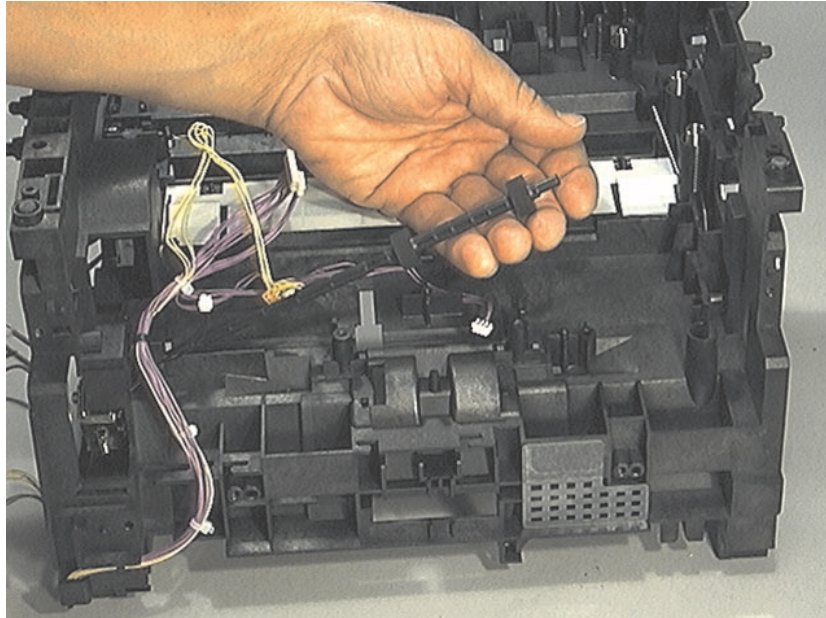

**Figure 4-53 Removing the Paper Feed Assembly (continued)**

- 6 Slide the Paper Feed Roller to the right and remove it from the printer chassis.

# 5

## Troubleshooting/Maintenance

### Chapter contents

Basic troubleshooting .....	116
Fatal errors/accessory errors .....	118
Image formation troubleshooting .....	121
Solving image quality problems .....	122
Cleaning procedures .....	135
Functional checks .....	138
ServiceMode functions (PJL Software Commands) .....	147
Troubleshooting tools .....	150

# Basic troubleshooting



Verification steps	Possible problems	Solutions
Is Power On successful?  When the product is connected to a grounded power source, the printer motor should rotate for approximately six seconds and the document scanner motor should rotate for approximately two seconds.	No power.	<ol style="list-style-type: none"> <li>1. Verify that the product is plugged in.</li> <li>2. Verify that the power cable is functional and that the power switch is on (220v only)</li> <li>3. Verify that FU102 on the ECU is not open.</li> <li>4. If all of these conditions are correct, replace the ECU.</li> </ol>
	Printer motor does not rotate.	<ol style="list-style-type: none"> <li>1. Verify that the toner cartridge is present.</li> <li>2. Verify that the printer door is closed.</li> <li>3. Verify that paper is loaded in the paper input bin.</li> <li>4. Verify that printer path paper sensors are functional.</li> <li>5. Verify that the motor connector J1 is seated into the ECU.</li> <li>6. Verify that the motor is correctly mounted to the printer chassis.</li> <li>7. If all of these conditions are correct, replace the ECU.</li> <li>8. If, after replacing the ECU, the printer motor still does not rotate, replace the motor.</li> </ol>
	Document scanner motor does not rotate.	<ol style="list-style-type: none"> <li>1. Verify that the document scanner connector is seated in the printer door.</li> <li>2. Verify that the document scanner is correctly mounted on the printer.</li> <li>3. If these conditions are met, replace the document scanner.</li> <li>4. If, after replacing the scanner, the document scanner motor still does not rotate, replace the formatter.</li> <li>5. If, after replacing the formatter, the document scanner motor still does not rotate, replace the ECU.</li> </ol>
Is the product ready?	Control panel displays an error light pattern."	Consult the list of common messages later in this chapter to correct the error.
The control panel should function without error messages	Control panel is not functional.	Verify that the control panel cable is seated into both the control panel and the formatter board. If the cable is connected correctly, replace the control panel.
Do engine tests and self tests print?	Engine test is not successful.	Replace the ECU.

<b>Verification steps</b>	<b>Possible problems</b>	<b>Solutions</b>
<p>Print an engine test, which is discussed later in this chapter. The engine test should print without paper feed problems or print quality problems. Also print self test (follow the instructions under "Printing self test" later in this chapter).</p>	Control panel displays an error light.	Consult the list of common messages in Chapter 2, or "Fatal errors" in this chapter to correct the error.
	Self test does not print.	If the engine test is successful, but self test does not print, replace the formatter.
	Paper does not move smoothly through the printer paper path	Isolate printer paper path problems by performing a paper path check, which is discussed later in this chapter.
	Poor print quality.	See "Solving image defects" later in this chapter.
Is the copy function operational?	Poor copy quality.	If the print quality from the self test and engine test was acceptable, but the print quality of the copies is not, clean the contact image sensor and the white roller, and then recalibrate the document scanner. If, after performing the maintenance, the problem persists, replace the contact image sensor or document scanner.
Place the self test into the document scanner input bin and copy it to the printer. Self test should feed smoothly through the document scanner path and copies should print without print quality problems.	Paper does not move smoothly through the document scanner path.	Clear the document scanner path of obstructions. Check photosensor to make sure that it operates correctly. If the problem persists, replace the document scanner.
Is the software installed correctly?	Software is not installed or an error occurred during software installation.	Uninstall the software. Reload the product's software. Make sure you use an ECP port setting.
Does the product print from the computer?	The parallel cable is not connected.	Connect the cable.
<p>Connect the parallel cable to the product and the computer. Use a word processing application to send a print job to the printer.</p>	An incorrect printer driver is selected.	Reset the printer driver.
	Other devices are connected to the parallel port.	Disconnect the other devices and try again to print.
	There is an LPT port driver problem in Windows 95/NT.	Reset the computer's port settings. Formatter failure - replace formatter.
	Does the product scan to the computer?	Other devices are connected to the parallel port.
<p>Initiate a scan from either the computer's basic desktop software or from the product.</p>	The computer's parallel port hardware is not bidirectional.	Check hardware documentation to see if the port configuration can be changed.
	The BIOS settings for the parallel port are set incorrectly.	Reset the computer's port settings. If the problem persists, reset the BIOS settings in CMOS.
	Polling is turned off in Document Assistant or Document Assistant is not running.	Start Document Assistant, turn on polling.

# Fatal errors/accessory errors



The printer may encounter a severe error, one that inhibits further operation. All LEDs will turn on, or in the case of an Accessory Error all LEDs will start flashing. During this mode, pressing and holding the Go key down will reveal a pattern on the LEDs. Some LEDs might be on and some might be off, but it will be a non-changing pattern as long as the Go key is held down. This pattern can be used to identify what type of fatal error it was. For example, if all LEDs turn on, holding the Go key down might turn off all of the LEDs except for the Attention LED. This pattern would indicate that there is an Engine Error. For most of the errors listed here, turning the printer off for a short while will not clear the error (it is more serious than that), but it is recommended as a last resort. Remember, the error pattern will only be displayed as long as the Go key is held down.

### Light status legend

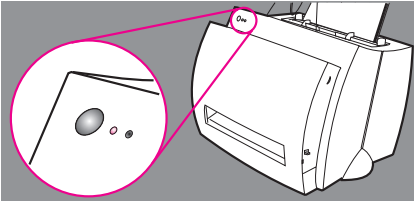



-  Symbol for "light off"
-  Symbol for "light on"
-  Symbol for "light blinking"



## Service and error messages

Light Status	Description	Recommended Action
	Beam Error: There are a number of causes for this error, and some of the causes may disappear.	<ol style="list-style-type: none"><li>1. Power cycle the printer by unplugging the printer and plugging it back in.</li><li>2. Make certain the Laser/Scanner Assembly is correctly seated on the printer chassis.</li><li>3. Replace the Laser/Scanner cable.</li><li>4. Replace the Laser/Scanner Assembly.</li><li>5. Replace the ECU.</li></ol>
	Print Engine Error: The formatter and engine are not communicating.	<ol style="list-style-type: none"><li>1. Power cycle the printer by unplugging the printer and plugging it back in. If this doesn't clear the error:</li><li>2. Reseat Formatter to ECU cable.</li><li>3. Replace the Formatter PCA.</li><li>4. Replace the ECU.</li></ol>
	Printer Laser/Scanner Error. Caused by a laser scanner malfunction.	<ol style="list-style-type: none"><li>1. Power cycle the printer by unplugging the printer and plugging it back in.</li><li>2. Ensure condensation caused by moving the printer from a cold to a warm environment hasn't occurred. Allow the printer to acclimate to the warmer room.</li><li>3. Verify the two Laser/Scanner Assembly connectors are firmly seated.</li><li>4. Replace scanner cable on the ECU.</li><li>5. Replace the Laser/Scanner Assembly.</li><li>6. Replace the ECU.</li></ol>

## Service and error messages

Light Status	Description	Recommended Action
	<p>Firmware Error:</p> <p>Note the LED patterns on the BiTronics error code. Contact HP technical support with this information as well as a description of what data was sent, the errors encountered prior to the firmware error, the condition of the printer prior to the error, and any other information that may help isolate the error.</p>	<ol style="list-style-type: none"><li>1. Power cycle the printer by unplugging the printer and plugging it back in.</li><li>2. Disconnect the parallel I/O cable and try running a printer self test. Reconnect the parallel cable if the self test is successful and try host/printer communications again.</li><li>3. If the error persists, replace the Formatter PCA.</li></ol>
	<p>Incompatible DIMM Error (Accessory Error)</p>	<p>Remove DIMM and power cycle. If error persists, replace formatter.</p>
	<p>Document Scan Engine Error</p>	<ol style="list-style-type: none"><li>1. Unplug the printer, remove and reattach the laser scanner, and then replug the printer.</li><li>2. Replace the document scanner unit.</li></ol>
	<p>Document Scan Engine NVRAM Error</p>	<ol style="list-style-type: none"><li>1. Unplug the printer, remove and reattach the laser scanner, and then replug the printer.</li><li>2. Replace the laser scanner unit.</li></ol>

---



# Image formation troubleshooting

## Checking the toner cartridge

Image formation defects are many times the result of toner cartridge problems. If there is any doubt, always replace the toner cartridge before troubleshooting image defects.

Use the following checklist to ensure that the toner cartridge is still operable.

Ensure that the toner cartridge is seated properly.

Inspect the toner cartridge for remaining toner.

Check the expiration date stamped on the toner cartridge box.

Check the toner cartridge to see if it has been disassembled or refilled.

Inspect the cartridge to see if toner is leaking through worn seals.

Check the surface of the photosensitive drum in the cartridge to see if it has been damaged or scratched. Touching the drum contaminates the photosensitive surface and can cause spotting and image defects.

Blurred areas on printed pages indicate that the photosensitive drum in the cartridge has been overexposed to light. Because overexposure to light causes permanent damage to the photosensitive drum, the cartridge should be replaced.

---

**Note**

---



A toner cartridge weighs 702 grams (24.7 ounces) when it is full and 594 grams (20.9 ounces) when it is empty.

### To redistribute toner in the cartridge

Before installing a new cartridge, or when toner begins to run low, redistribute the toner by rotating the cartridge back and forth five or six times.



## Solving image quality problems

Use the following table to help solve problems with printed pages. See “Solving paper feed problems” in this chapter.

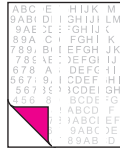

Problem	Cause	Solution
Parts of the page around the edges aren't printing.	The HP LaserJet 1100 cannot print to the edge of the paper. The HP LaserJet 1100 has minimum margins on each edge of 0.25 in (6.4 mm).	To get the image to fit into this printable area, slightly reduce the size of the image.
	If printing or copying, the reduction setting is set incorrectly.	For printing, check the reduction setting in the “Print” or “Setup” window from within the program you are using. Copies will clip if original has image too close to edge.
Images will not print.	The HP LaserJet 1100 is not plugged in.	Make sure that the HP LaserJet 1100 is plugged into a live wall outlet or power strip.
	The parallel cable is loose.	Check that the parallel cable is securely connected between the HP LaserJet 1100 and the computer.
Copies or scanned images are too light or too dark.	The contrast is not set correctly.	Adjust the contrast and resolution settings from the Document Assistant.
	The HP LaserJet 1100 needs to be recalibrated.	Recalibrate the product.
	The original image is very light or very dark.	Adjust the resolution and/or contrast setting(s) from the tool box on the Document Assistant.
	The scanned image is too light or too dark because the original was on a colored paper.	If the original was on a colored paper, including brown recycled paper, the text may not be clear. Adjust the resolution, contrast, and/or brightness settings from the tool box on the Document Assistant.



Problem	Cause	Solution
Print is faded or you notice a block of vertically aligned white streaks,	The toner cartridge is getting low on toner.	Redistribute the toner or replace the toner cartridge.
	The HP LaserJet 1100 needs to be cleaned.	See "Cleaning procedures" in this chapter.
or print is not faded, but vertical white stripes appear on the page.	The paper you are using does not meet HP's paper specifications (for example, it is too moist or too rough).	Make sure that the media meets specifications detailed in HP's media specifications guide.
	Toner density setting is not adjusted correctly.	Adjust the setting from the control panel.
	A part of the HP LaserJet 1100 is damaged.	Follow the steps in "Basic troubleshooting" to isolate the problem.
	The internal mirror or optics are damaged.	Clean the mirror by blowing air through the laser/scanner to remove any dust particles.
	The laser/scanner is damaged.	Replace the laser/scanner.
	There is a problem in the contact image sensor.	Follow the instructions in this chapter to recalibrate the document scanner.
	The document scanner needs to be recalibrated.	Replace the contact image sensor
	There is a problem in the formatter.	Replace the formatter.



Problem	Cause	Solution
Stains or smudges appear as small, round, black dots on the front or back of a page. Sometimes inconsistent stains appear.	The paper you are using does not meet HP's paper specifications (for example, it is too moist or too rough).	Make sure that the media meets specifications detailed in HP's media specifications guide.
	You are printing on the wrong side of the paper.	Remove the paper from the paper input bin and turn it over. (The wrapper on many reams of paper has an arrow indicating the print side.)
	The HP LaserJet 1100 needs to be cleaned.	See "Cleaning procedures" in this chapter for instructions on cleaning the product and using a cleaning page.
	The toner cartridge is damaged.	Replace the toner cartridge if maintenance procedures do not improve print quality.
Vertically-aligned black streaks or smears appear on successive pages.	The HP LaserJet 1100 needs to be cleaned.	See "Cleaning procedures" in this chapter.
	The toner cartridge is damaged.	Replace the toner cartridge if maintenance procedures do not improve print quality.
	There is a problem in the heating element.	Perform the "Heating element check," which is discussed later in this chapter.
	If scanned images have unwanted lines through them:	
	There is ink, glue, white-out, or some other substance on the contact image sensor.	See "Cleaning procedures" in this chapter.
	Slick paper caused the document scanner trouble in scanning.	Use a carrier sheet to send the item.
	The HP LaserJet 1100 needs to be recalibrated.	Recalibrate the product.

<b>Problem</b>	<b>Cause</b>	<b>Solution</b>
<p>Horizontally aligned black streaks or smears appear.</p> 	The toner cartridge was improperly installed.	Make sure you removed the entire length of the sealing tape from the toner cartridge before you installed it.
	The toner cartridge is defective.	Replace the toner cartridge.
	The HP LaserJet 1100 needs to be cleaned.	See "Cleaning procedures" in this chapter.
	There is a problem in the heating element.	Perform the "Heating element check," which is discussed later in this chapter.
	A gear is damaged.	Perform the "Drum rotation functional check," which is discussed later in this chapter.
	There is a problem in the laser/scanner.	Replace the laser/scanner.
	The HP LaserJet 1100 needs to be cleaned.	See "Cleaning procedures" in this chapter.
	There is a problem in the contact image sensor.	Replace the contact image sensor.
	A roller is damaged.	Use the "Repetitive image defect ruler" later in this chapter to determine which roller is damaged. Replace the roller.
	The HP LaserJet 1100 needs to be cleaned.	See "Cleaning procedures" in this chapter.
If you are using transparencies, they do not meet HP's specifications.	Make sure that the media meets specifications detailed in HP's media specifications guide.	
The paper's texture is too coarse.	Try changing to a paper with a smoother finish.	
The toner cartridge is damaged, causing a repetitive black flaw on every printout.	Replace the toner cartridge.	
The toner cartridge's photosensitive drum has been overexposed to bright light, causing repetitive defects (usually a fuzzy black area).	Replace the toner cartridge.	

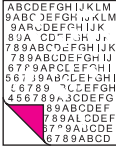
<b>Problem</b>	<b>Cause</b>	<b>Solution</b>
Character voids appear (white areas within the parts of characters that should be solid black).	The paper or transparencies do not meet HP's specifications.	Make sure that the media meets specifications detailed in HP's media specifications guide.
	You are printing on the wrong surface of the paper.	Remove the paper and turn it around. (The wrapper on many reams of paper has an arrow indicating the print side.)
	Poor fusing	Check for wrap jam in fuser.
	Background scatter results from bits of toner distributed on the front or back of a printed page. Background scatter often is isolated to a specific area of the page.	Try changing the print density setting. If that doesn't work, change the paper type, weight, or surface finish. If background scatter occurs on an envelope, try moving the text to an area with no seams. Printing on seams can cause this problem.
	Toner has spilled inside the product.	See "Cleaning procedures" in this chapter.
	The pickup roller is dirty.	See "Cleaning procedures" in this chapter.
The page is completely black.	The toner cartridge was improperly installed.	Remove the cartridge and reinstall it.
	The toner cartridge is defective.	Replace the toner cartridge.
	Discontinuity exists in the high-voltage contact points.	Perform the "High-voltage power supply check," which is discussed later in this chapter.
	There is a problem in the ECU or the laser/scanner.	Follow the steps in "Basic troubleshooting" to isolate the problem. Replace the ECU or the laser/scanner, as needed.

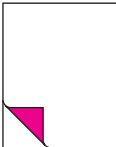
Problem	Cause	Solution
Characters are only partially printed (also referred to as dropouts).  	A single sheet of paper is defective.	Try reprinting the job.
	The print density needs to be adjusted.	Adjust the print density from the control panel.
	The moisture content of the paper is inconsistent or the paper has moist or wet spots on the surface.	Make sure that the media meets specifications detailed in HP's media specifications guide.
	The paper was damaged by inconsistent manufacturing processes.	Make sure that the media meets specifications detailed in HP's media specifications guide.
The bottom of the printed page is blank or part of a graphic's image is cut off.  	A "draft mode" or "economy mode" is selected in the software.	Try a "normal" or "best" setting.
	The page is too complex. (There is not enough memory to process the page.)	Set the resolution to 300 dpi through your software or printer driver. See the online help for printer driver issues.
Blank pages print occasionally.  	Page length and margins are not set correctly for the paper size.	If you are printing on small paper and your page is blank, try printing on larger paper to see where the image is printing. Adjust the margins accordingly.

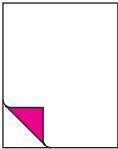
Problem	Cause	Solution
	Your HP LaserJet 1100 is feeding two or more sheets of paper at a time because the paper is difficult to separate	Remove the paper from the paper input bin and align the edges of the paper. "Break" the ream of paper by curving it into an upside-down u-shape. Try turning the paper around to feed the other end first, or use a different type of paper.  Clean the pickup roller and the separation pad. If the problem persists, replace the separation pad or subpads
	Your software application is sending an extra page-eject command.	Check your software's printing configuration information. If you are using a word-processing program, check for a natural page break and a forced page break that are close to each other.
Blank pages are always printing	The toner cartridge was improperly installed.	Make sure you removed the entire length of the sealing tape from the toner cartridge before you installed it.
	The toner cartridge is completely out of toner.	Replace the toner cartridge.
	Discontinuity exists in the high-voltage contact points.	Perform the "High-voltage power supply check," which is discussed later in this chapter.
	There is a problem in a part of the product.	Print a self-test page. If the page is blank, follow the steps in "Basic troubleshooting" to isolate the problem. Replace the laser/scanner or the ECU as needed.



---



---

Problem	Cause	Solution
---------	-------	----------

Print is misaligned on the page (skewed pages).

The paper input bin is overfilled.

Remove some of the paper.



The guides are adjusted improperly.

Be sure to center the paper with the paper guides. Also, verify that the paper guides are not adjusted too tightly or too loosely against the paper.

The paper's weight or surface finish does not meet HP's specifications.

Make sure that the media meets specifications detailed in HP's media specifications guide.

Scanned images have black dots or streaks in top and bottom margins.

There is ink, glue, white-out, or some other substance on the contact image sensor.

See "Cleaning procedures" in this chapter.



There is a problem in the contact image sensor.

Replace the contact image sensor.

Scanned text is not clear.

The contrast, resolution, or brightness needs to be adjusted before scanning.

Adjust the resolution, contrast and/or brightness setting(s) from the tool box on the Document Assistant.



---

---

<b>Problem</b>	<b>Cause</b>	<b>Solution</b>
	The original is on colored paper.	If the original was on colored paper, including brown recycled paper, the text may not be clear. Try adjusting the resolution, contrast, and/or brightness settings from the tool box on the Document Assistant.
	There is a problem in the contact image sensor.	Replace the contact image sensor.

---

# Solving paper feed problems

Use the following table to solve problems related to moving paper or documents through the HP LaserJet 1100.

---

<b>Problem</b>	<b>Cause</b>	<b>Solution</b>
Pages are coming out curled or wrinkled from the HP LaserJet 1100.	Paper is curled or wrinkled when using the paper output bin.	Use the front paper output slot by pushing the paper path lever to the lower position.
	Paper is not stored properly.	Whenever possible, store paper in its sealed ream at room temperature.
Long pages stop feeding through the document scanner.	The document feeder tray guides are not set correctly, are broken, or are missing.	Check for broken or missing document feeder tray guides and replace as necessary.
	The maximum scannable page length is 30 inches (991 mm). If the page is longer, scanning stops at 30 inches (991 mm).	Do not try to pull the page out because you may damage the document scanner. To remove the page, open the document release door and remove the jammed media.
Print is misaligned on the page (skewed pages).	The paper input bin is overfilled.	Remove some of the paper.
	The paper guides are not set correctly, are broken, or are missing.	Be sure to center the paper with the guides. Verify that the guides are not adjusted too tightly or too loosely against the paper. Check for broken or missing paper guides and replace scanner as necessary.
	The paper's weight or surface finish does not meet HP's specifications.	Make sure that the media meets specifications detailed in HP's media specifications guide.

<b>Problem</b>	<b>Cause</b>	<b>Solution</b>
Scanned items are crooked.	The document feeder tray guides are not adjusted properly.	Be sure to center the paper with the guides. Also, verify that the guides are not adjusted too tightly or too loosely against the paper. Check for broken or missing document feeder tray guides and replace scanner as necessary.
The HP LaserJet 1100 is feeding multiple sheets or jams frequently from the paper input bin or single-sheet input slot.	Paper guides are not adjusted properly.	Slide the guides against the sides of the stack in the paper input bin or against the single sheet in the single-sheet input slot to center the paper. Make sure the guides are not adjusted too tightly.
	Paper was not removed from the paper input bin before filling the bin.	Always remove paper from the paper input bin before refilling the bin.
	The paper input bin is overfilled.	Remove some of the sheets. The paper input bin can hold up to 125 sheets of 20-lb. (75g/m <sup>2</sup> ) bond weight paper (less for heavier paper) or from 7 to 10 envelopes.
	More than one sheet was placed in the single-sheet input slot.	Place only one sheet at a time in the single-sheet input slot.
	The paper was poorly cut by the manufacturer and is sticking together.	"Break" the ream of paper by curving it into an upside-down u-shape; this may effectively decrease multifeeds. Also try turning the paper around to feed the opposite end first, or use a different type of paper.
	The paper does not meet HP's specifications for print media.	Make sure that the media meets specifications detailed in HP's media specifications guide.
	The output capacity was exceeded in the paper output bin or front paper output slot.	Do not allow more than 100 sheets of 20-lb (75g/m <sup>2</sup> ) bond weight paper (less for heavier paper) to fill the paper output bin.
	The pickup roller is dirty.	See "Cleaning procedures" in this chapter.
The pickup roller is damaged.	Replace the pickup roller.	

<b>Problem</b>	<b>Cause</b>	<b>Solution</b>
	The separation pad is dirty.	Clean the separation pad.
	The separation pad is damaged.	Replace the separation pad.
	A sensor isn't operating properly.	Check the sensors to make sure that none of them are jammed. If a sensor cannot be "unjammed," replace the sensor.
	There is a problem in the paper path.	Perform the "Paper path check," which is discussed later in this chapter, to determine which parts should be replaced.
The HP LaserJet 1100 is feeding multiple sheets or jams frequently from the document feeder tray.	Guides are not adjusted properly.	Remove the document from the document feeder tray. Straighten the item, then reinsert it. Slide the guides against the sides of the item to center it. Make sure the guides are not adjusted too tightly.
	The document feeder tray is overfilled.	Remove some of the sheets. The document feeder tray can hold up to 10 pages, depending on the thickness of the pages.
	The item was too thick, too slick, or otherwise did not meet specifications.	Make sure that the media meets specifications detailed in HP's media specifications guide.
	The document scanner pickup roller or separation pad is dirty and cannot feed the document.	See "Cleaning procedures" in this chapter.
	The document scanner pickup roller or separation pad is damaged or worn.	Replace the scanner.
	The sensor isn't operating properly.	Check the sensor to make sure it is not jammed. If a sensor cannot be "unjammed," replace the scanner.
	There is a problem in the document scanner path.	Check the path for obstructions. Readjust as necessary or replace the scanner.

---

---

<b>Problem</b>	<b>Cause</b>	<b>Solution</b>
Items loaded in the document feeder tray fall forward out of the tray.	The item is on a very lightweight media.	Do not try to pull the page out because you may damage the document scanner. Open the document release door and remove the jammed media. Then, curl or roll the item in the direction of the printed side, unroll it, and reload the item.

---

## Cleaning procedures

### Cleaning the toner cartridge area

With a dry, lint-free cloth, wipe any residue from the paper path area and the toner cartridge cavity.

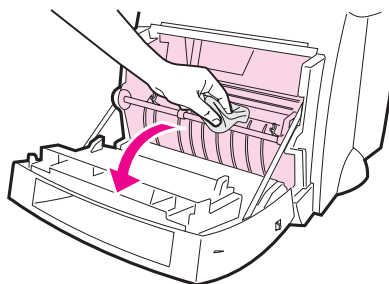

---

**Note**

---

Cleaning the toner cartridge area is not necessary on a regular basis. Before cleaning, look for excessive toner in the compartment.

### Cleaning the printer paper path

This process uses copier-grade paper to remove dust and toner from the paper path. Do not use bond or rough paper. Use this process if you are experiencing toner specks or dots on printouts. This process will produce a page with toner debris, which should be discarded.



- 1 Ensure the printer is loaded with paper.
- 2 Ensure the printer is in the Ready state.
- 3 Press and hold the **GO** key for 20 seconds (if released before 20 seconds the printer will perform a reset). Paper will feed through the printer.

---

**Note**

---

After holding the **GO** key for 20 seconds, each of the three printer lights will blink until the cleaning process is complete.

### Cleaning the pickup roller

To clean the pickup roller rather than replace it, follow the instructions below:

- 1 Remove the pickup roller as described in "Changing the pickup roller."
- 2 Dab a lint-free cloth in isopropyl alcohol, and then scrub the roller.

---

**WARNING!**

---

Alcohol is flammable. Keep the alcohol and cloth away from open flame. Allow alcohol to dry completely before closing the printer and plugging in the power cord.

- 3 Using a dry, lint-free cloth, wipe the pickup roller to remove loosened dirt.

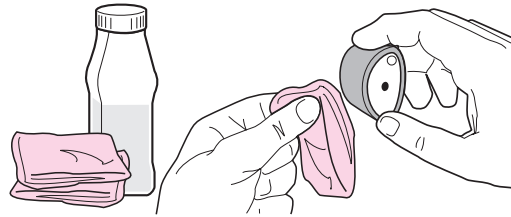

- 4 Allow the pickup roller to completely dry before reinstalling it in the printer.

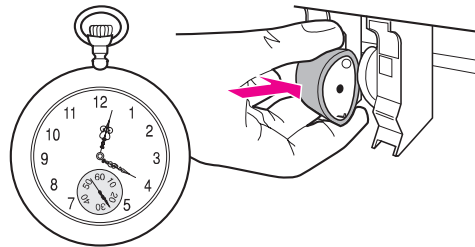

## Cleaning the scanner

You may need to clean the scanner after scanning or copying items that have ink which smudges or that have excessive amounts of dirt or dust.

To clean the scanner, follow the instructions below:

- 1 Unplug the printer to turn the power off, and then wait for the scanner to cool.

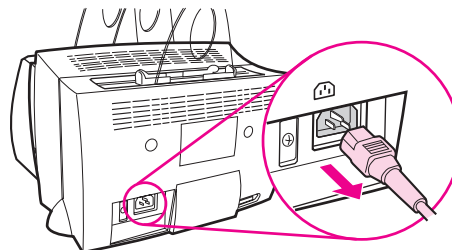

- 2 Open the scanner door.



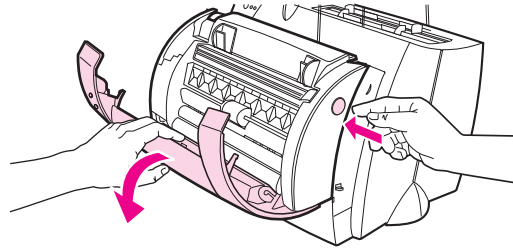

- 3 Dampen a clean, cotton cloth with rubbing alcohol (pH7 or neutral pH) or glass cleaner. Gently rub back and forth on the white CIS roller with the damp cloth while slowly turning the CIS roller.

---

**WARNING!**

---

Alcohol is flammable. Keep the alcohol and cloth away from open flame. Allow alcohol to dry completely before plugging in the power cord.

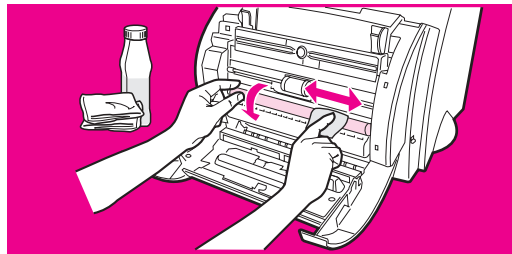

- 4 Spray **glass cleaner** on another piece of clean, cotton cloth and carefully clean the glass on the image sensor.

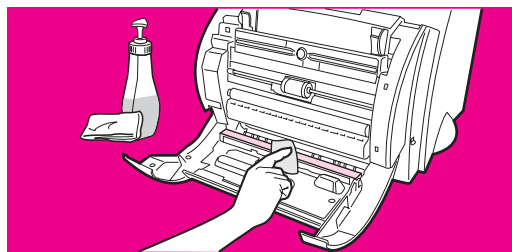

---

**WARNING!**

---

Ensure the scanner is completely dry before plugging in the printer power cord.

# Functional checks

## Engine test

The engine test is used to verify that the print engine is functioning correctly. The formatter is bypassed during an engine test, so the engine test is useful for isolating printer problems. The engine test prints vertical lines down the entire printable area of a page and is also useful for checking and adjusting registration.

## Engine test button location

The engine test switch is accessible without removing the covers. It is located on the back of the HP LaserJet 1100 under the memory door.

New picture here: now behind memory door on back of printer

## Printing an engine test

To print an engine test, lift the memory door on the back of the printer and depress the engine test switch (Figure 5-1). A single test page will print.

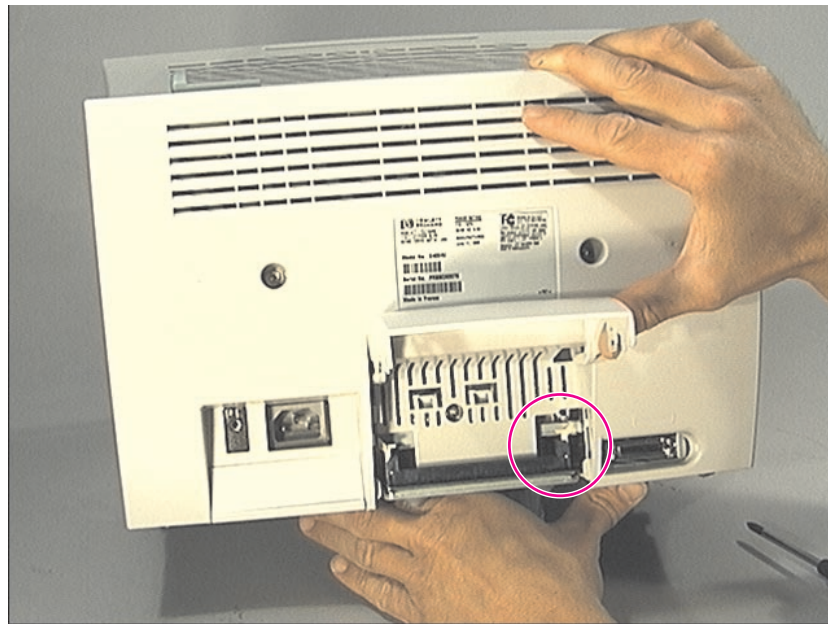

**Figure 5-1 Engine Test Switch**

## Self test page

The Self Test Page (Figure 5-2) printout provides both a means of testing the printer and a way of displaying the printer's configuration. The Self Test Page Printout does not run a diagnostic Self Test (unlike previous printers) but it still tests the functionality of the printer by being able to format data and place it accurately on the page.

Some graphic images are available to make the page more visually pleasing. The configuration is printed next. This configuration is the PJP configuration that PCL will use. This includes such items as PaperSize, Orientation and Copies, etc.

### Figure 5-2 Self Test Page

If there are any downloaded "permanent" fonts (not "temporary" fonts), other pages are printed out showing these fonts. Each font will provide a sample of the font, the font ID, the typeface, the style, the stroke weight, the size (not applicable if the font is a scalable), and whether it is Fixed pitch or Proportional spacing.

If the memory is too low, a reduced Self Test Page is printed which contains only the printer configurations and a message "Reduced Self Test Printed - Memory Too Low." In a low-memory condition the font printout attempts to print all downloaded

permanent fonts, but if the memory is too low a message “Font Test Aborted” is printed. In some low-memory situations a reduced Self Test Page may be printed, but the font printout may have enough memory to print all downloaded permanent fonts.

## Half-self test functional check

The electrophotographic process can be subdivided into the following stages:

- Image formation stage (charges the drum and writes a latent image to the drum with the laser)
- Development stage (forms a toner image on the drum)
- Transfer stage (transfers the image to paper)
- Cleaning stage (removes excess toner from the drum)
- Fixing stage (applies heat and pressure to make the image on paper permanent)

The purpose of the half-self test check is to determine which process is malfunctioning. Perform the test as follows:

- 1 Initiate a self test.
- 2 Open the printer door after the paper advances half-way through the printer (about 8 seconds after the motor begins rotation). The leading edge of the paper should have advanced past the toner cartridge.
- 3 Remove the toner cartridge.
- 4 Open the toner cartridge drum shield to view the drum surface. If a dark and distinct toner image is present on the drum surface, assume that the first two functions of the electrophotographic process are functioning (image formation and development). Troubleshoot the failure as a transfer or fixing problem.

If there is no image on the photosensitive drum, perform the following functional checks:

- 1 Make sure you have removed the entire length of the sealing tape from the toner cartridge before you installed the cartridge.
- 2 Perform a drum rotation functional check.
- 3 Perform a high-voltage power supply check.

## Drum rotation functional check

The photosensitive drum, located in the toner cartridge, must rotate for the print process to work. The photosensitive drum receives its drive from the main drive assembly. To verify that the drum is rotating:

- 1 Open the printer door.
- 2 Remove the toner cartridge.
- 3 Mark the drive gear on the cartridge with a felt-tipped marker. Note the position of the mark.
- 4 Install the toner cartridge and close the printer door. The start-up sequence should rotate the drum enough to move the mark.
- 5 Open the printer and inspect the gear that was marked in step 3. Verify that the mark moved.

If the mark did not move, inspect the main drive assembly to make sure that it is meshing with the toner cartridge gears. If the drive gears appear functional and the drum does not move, replace the toner cartridge.

---

**Note**

---

This test is especially important if refilled toner cartridges have been used.

## Heating element check

Paper passes between the heating element and a soft pressure roller to fuse toner to the paper. To verify that the heating element is functioning correctly:

- 1 Unplug the HP LaserJet 1100 for at least ten minutes.
- 2 Verify that the thermistor connector (Figure 5-3) is seated into both the printer chassis and the ECU (for printer disassembly instructions, see Chapter 4, "Removal and replacement."

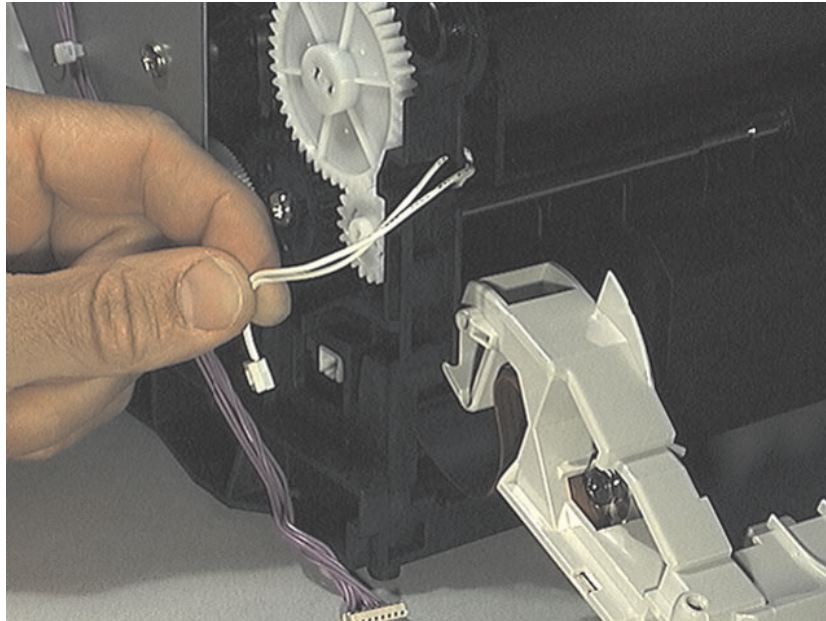

**Figure 5-3 Thermistor Connector**

- 3 Remove the heating element connector (Figure 5-4) from the ECU. To measure the continuity of the heating element, measure the resistance between the two pins at the end of the cable.

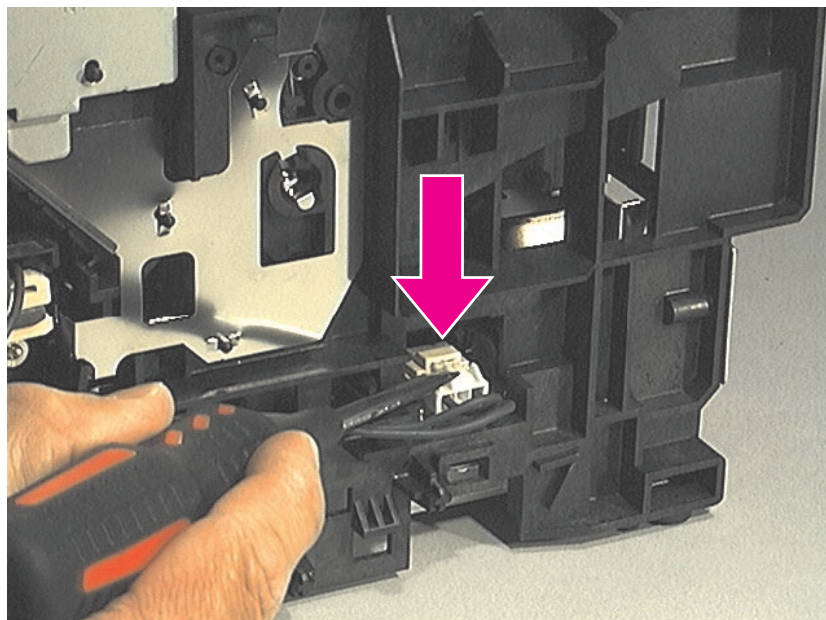

**Figure 5-4 Heating Element Connector**

---

**Note**

---

Normal resistance is 30 ohms +/- 10 ohms.

- 4 If no resistance is measured, replace the heating element.
- 5 Remove the thermistor connector (Figure 5-3) and measure the resistance between pins one and two.

---

**Note**

---

Normal resistance is 440K ohms +/- 30K ohms at 68° F (20° C).

- 6 If no resistance is measured, replace the heating element.

## High-voltage power supply check

The high-voltage power supply PCA provides the necessary voltages for the electrophotographic processes.

### Checking the toner cartridge connection points

Visually inspect the three connection points on the underside, right end of the toner cartridge: charging (callout 1), drum ground (callout 2), and developing roller (callout 3). If they are dirty or corroded, clean the connections, or, if they are damaged, replace the toner cartridge.

---

**Note**

---

Use only alcohol to clean the connections.

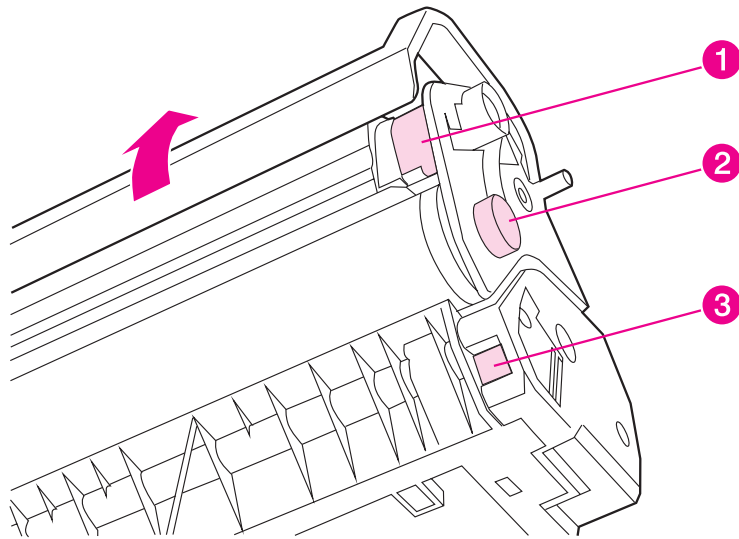
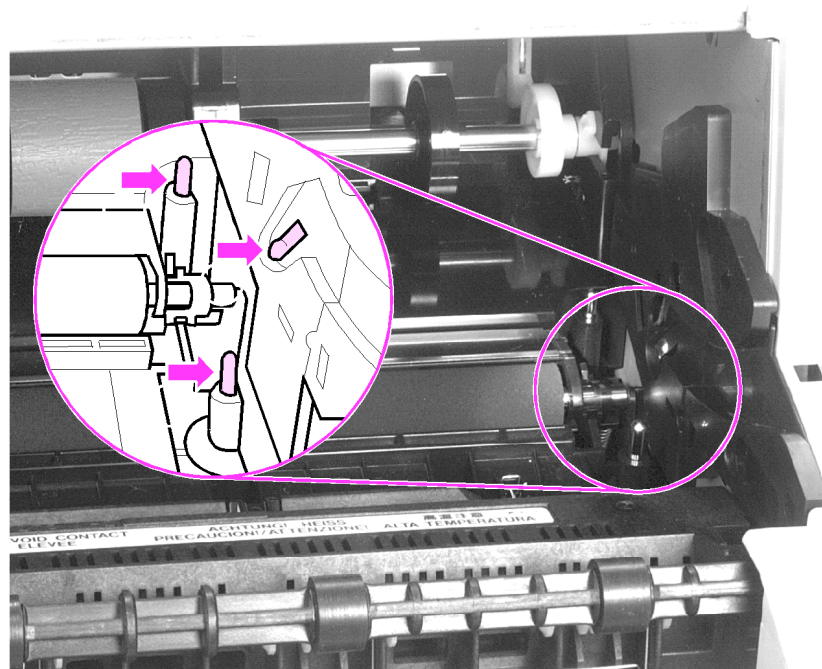

**Figure 5-5 Toner cartridge high-voltage connection points**

### Checking the high-voltage connector assembly

The assembly uses three spring-loaded pins to contact the toner cartridge: charging (callout 1), drum ground (callout 2), and developing roller (callout 3). Verify that the pins are not dirty or corroded and that the spring-loading action is functional. If the pins are dirty, clean them using alcohol only. If they are damaged, replace the high voltage connector assembly.





**Figure 5-6 High-voltage connector assembly**

## **Paper curl**

Paper curl is inherent to the laser printing processes, and occurs when paper is subjected to heat. Paper curl tends to relax as the paper cools while resting on a flat surface. The specification for maximum paper curl when the paper is lying flat before print is 0.2 inches (5 mm).

## **Paper path check**

If paper is not being picked up or is not moving through the paper path, you may want to observe all of the paper motion activities. Overriding SW301 allows you to observe:

- Motor rotation
- Solenoid action
- Kick plate motion
- Paper pickup roller motion
- Drive roller, transfer roller, fuser roller and gear, and delivery roller motion

## To override SW301

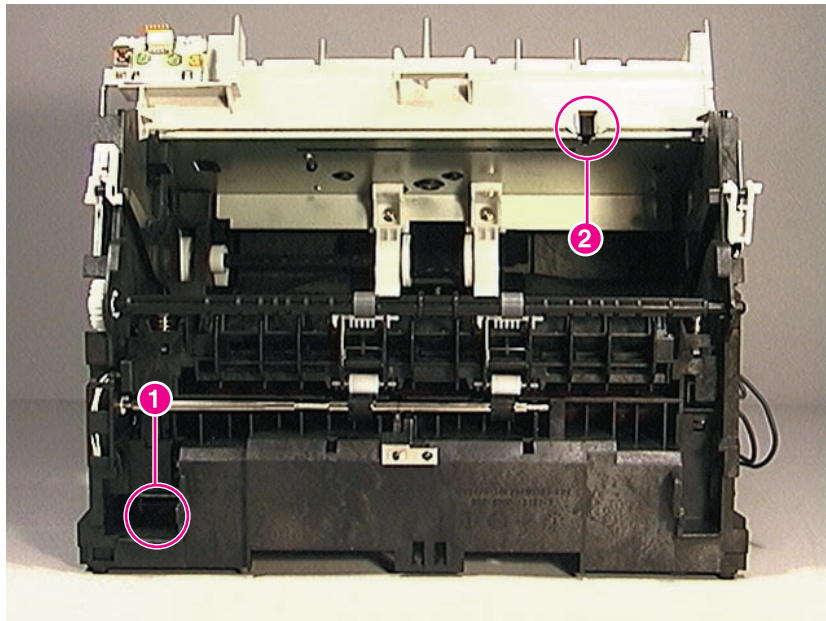

**Figure 5-7 Overriding SW301**

- 1 Remove the printer covers.
- 2 Make sure the fuser levers on the Delivery Assembly are closed.
- 3 Press SW301- front door interlock (callout 1).
- 4 Press Laser/Scanner Interlock Switch on Laser/Scanner (callout 2)
- 5 While SW301 and Laser/Scanner Interlock is engaged, perform an Engine Test to observe paper motion. (See procedures earlier in this chapter.)

## ServiceMode functions (PJL Software Commands)

To set the following NVRAM variables:

Factory printer DEFAULT PAPER, scanner factory default paper size will be set to the same value automatically if one is attached.

Factory printer DEFAULT LPARM:PCL SYMSET.

Factory DEFAULT OEM bit.

Factory DEFAULT PRINTPAGECOUNT

Factory DEFAULT SCANPAGECOUNT if scanner is attached.

Factory DEFAULT COPYPAGECOUNT if scanner is attached.

NOTE: Default quick copy paper size is also stored in scanner NVRAM but is changed only with software or set back to factory default with a NVRAMINIT. Quick copy image type, and contrast only have a default value stored in NVRAM, and can only be changed with the software or by NVRAMINIT, which returns them to a ROM default value.

NVRAMINIT, sets all default variables stored in NVRAM back to factory default values, or a default ROM value depending on the variable, and performs a system reset. This can be done also be done manually by turning off the printer, hold down the GO key, turn on the printer. You will see the all the LED's flash once, then turn off. Keep the Go key held down until you see the LED's cycle once then release it. This will cause the LED's to cycle twice as fast after the RAM/ROM checks than normal and the NVRAM variables will be set back to the factory defaults.

---

**Note**

---

NVRAMINIT will not clear page counts

Figure 5-8 provides a more detailed description of the NVRAM PJL factory variables and commands, and how they are used.

<b>NVRAM PJJ Variable or Command</b>	<b>Possible settings</b>
<b>DEFAULT PAPER</b>	"LETTER", "LEGAL", "A4", "EXECUTIVE", "COM10", "MONARCH", "DL", "C5", "B5", "CUSTOM"
<b>DEFAULT LPARM:PCL SYMSET</b>	"ROMAN8", "ISOL1", "ISOL2", "ISOL5", "PC8", "PC8DN", "PC850", "PC852", "PC8TK", "WINL1", "WINL2", "WINL5", "DESKTOP", "PSTEXT", "VNINTL", "VNUS", "MSPUBL", "MATH8", "PSMATH", "VNMATH", "PIFONT", "LEGAL", "ISO4", "ISO6", "ISO11", "ISO15", "ISO17", "ISO21", "ISO60", "ISO69", "WIN30"
<b>DEFAULT OEM</b>	"ON", "OFF"
<b>DEFAULT PRINTPAGECOUNT</b>	0-2147483647
<b>DEFAULT SCANPAGECOUNT</b>	0-2147483647
<b>DEFAULT COPYPAGECOUNT</b>	0-2147483647
<b>CLEARNVRAM</b>	None - Command
<b>NVRAMINIT</b>	None - Command

**Figure 5-8 NVRAM PJJ Factory Variables**

To use these commands you need some method of sending PJJ commands to the printer, either with a software tool or by copying down a binary file containing the commands from the host using a DOS box. For example from the DOS prompt:

```
copy /b filename lpt1
```

Here is an example file that uses one of the commands:

```
ESC%-12345X@PJJ SET SERVICEMODE=HPBOISEID

@PJJ 'command'

@PJJ RESET
```

Here is an of using the NVRAMINIT command:

```
ESC%-12345X@PJJ SET SERVICEMODE=HPBOISEID

@PJJ NVRAMINIT

@PJJ RESET
```

Note: remember to set SERVICEMODE before trying to set the variable or you will not get the desired result. The PJJ reset is also necessary to be sure the SERVICEMODE status is cleared.

To create these files you will need a editor that can insert the ESC character, or be able to copy it in from a existing file. If a software tool is used, just send down the same strings, in the same order as given for the example files.

# Troubleshooting tools

## Printer paper path

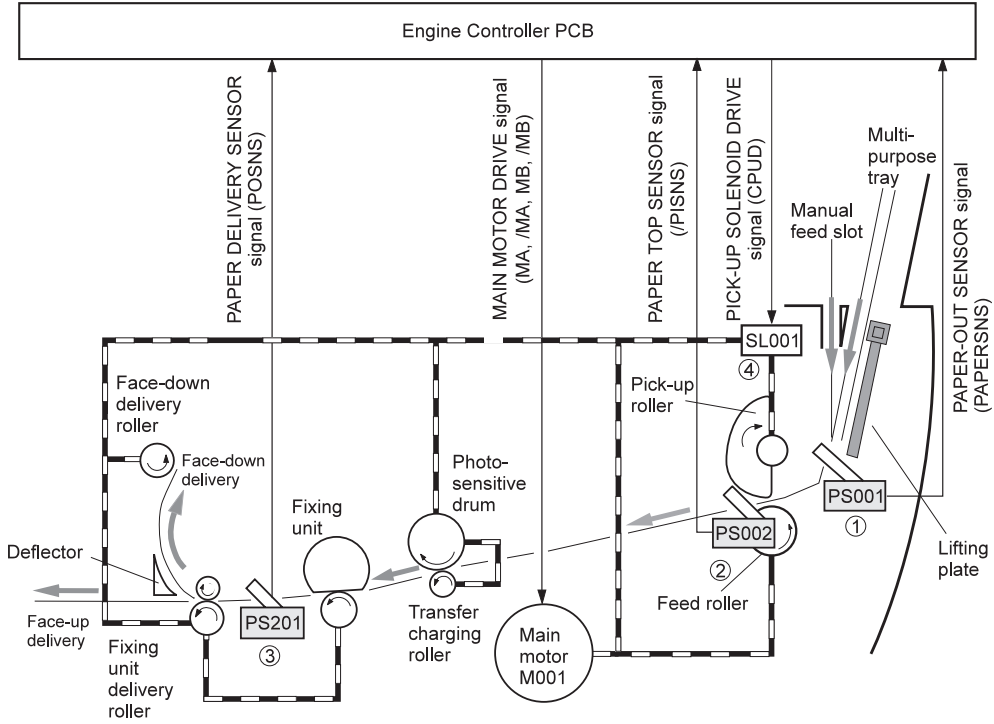

Figure 5-9 Paper path and components

## Document paper path

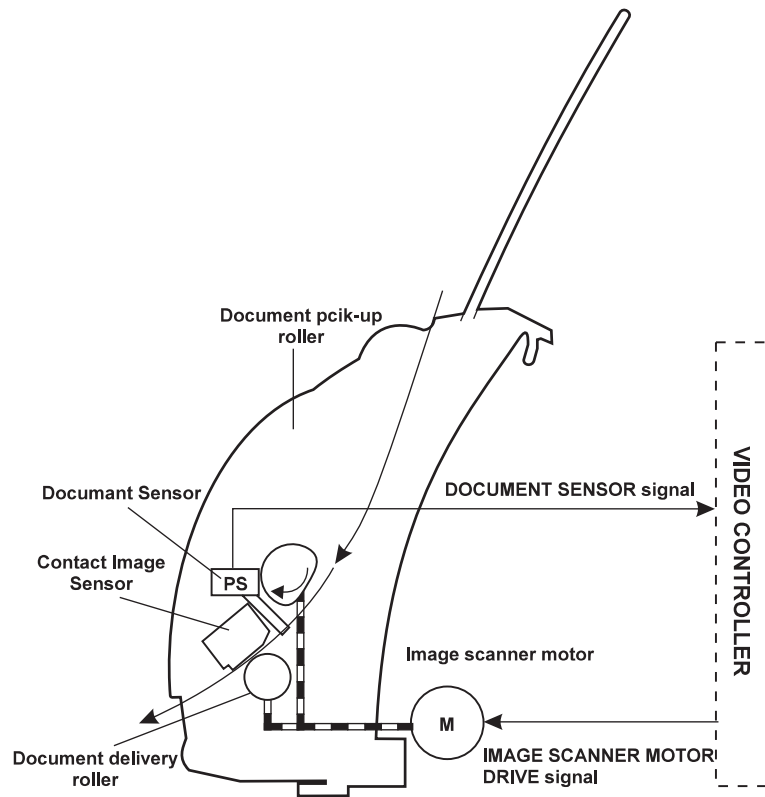
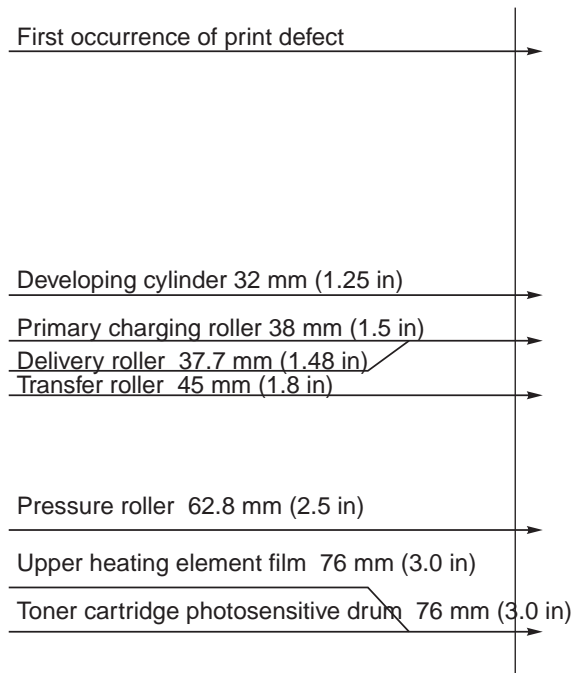

Figure 5-10 Document path and components

## Repetitive image defect ruler



## Repetitive image defect ruler



# Main wiring

## II. GENERAL CIRCUIT DIAGRAM

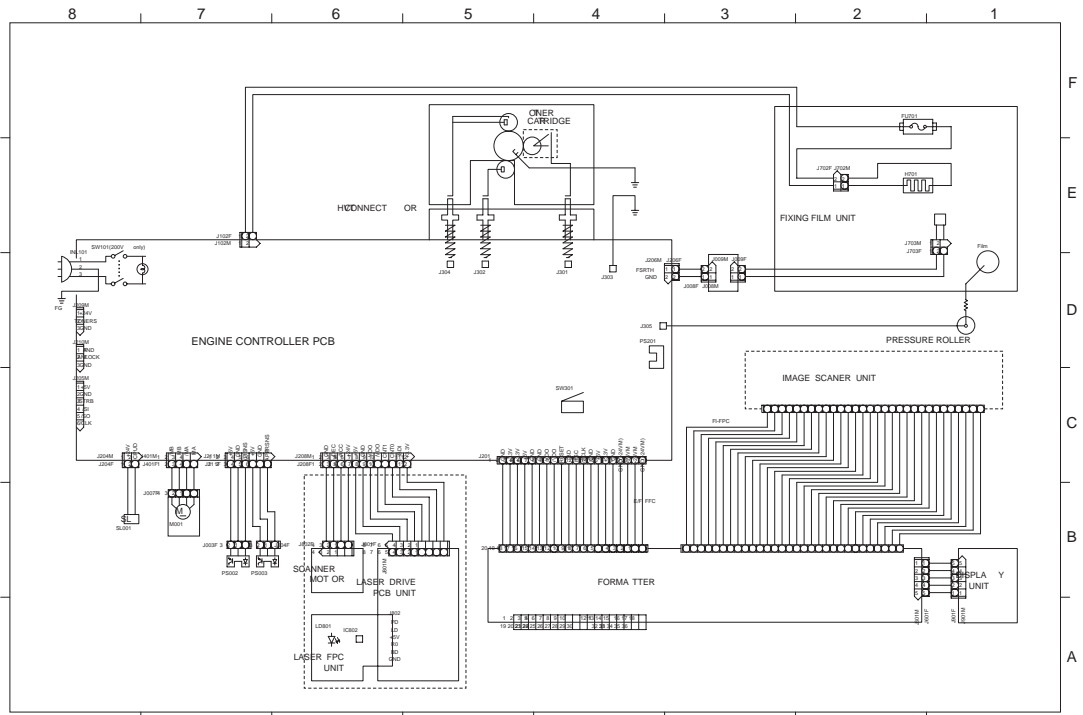

A 2



# 6

## Parts and diagrams

### Chapter contents

How to use the parts lists and diagrams . . . . .	156
Parts and supplies . . . . .	157
Ordering Information . . . . .	158
Consumables and accessories . . . . .	159

# How to use the parts lists and diagrams

The figures in this chapter illustrate the major subassemblies in the printer and their component parts. A table (material list) follows each exploded assembly diagram. Each table lists the reference designator, the associated part number for the item, and a description of the part.

While looking for a part number, pay careful attention to the voltage listed in the description column to make sure that the part number selected is for the correct model of printer.

# Parts and supplies

## Ordering parts

Replacement parts may be ordered from HP's Support Materials Organization (SMO) or Support Materials Europe (SME).

Use only accessories specifically designed for this printer. Accessories can be ordered from an authorized service or support provider.

All standard part numbers listed are stocked and may be ordered from HP's Support Materials Organization (SMO), or Support Materials, Europe (SME).

- Hewlett-Packard Co.  
Support Materials Organization  
8050 Foothills Blvd.  
Roseville, CA 95678  
Parts Direct Ordering: (800) 227-8164 (U.S. Only)
- Hewlett-Packard Co.  
Support Materials, Europe  
Wolf-Hirth Strasse 33  
D-7030 Boblingen, Germany  
(49 7031) 14-2253

You can also contact Hewlett-Packard at (916) 783-0804 to find out part numbers for the HP LaserJet 3100 product. Contact a local HP Parts Coordinator for other local phone numbers.

## Ordering Information

You can increase the capabilities of the printer with optional accessories and supplies. Use accessories and supplies specifically designed for the HP LaserJet 1100 Printer and the HP LaserJet 1100A Printer•Copier•Scanner to ensure optimum performance.

## Consumables and accessories

The following items are available through a local authorized HP dealer. To find a dealer near you (or if your dealer is temporarily out of stock), call the HP Customer Information Center at (800) 752-0900.

DESCRIPTION	PART #	EST. LIFE (PAGES)	REMARKS
Toner cartridge (user replaceable)	C4092A	2,500	When print becomes faint, redistribute toner in the cartridge.
Printer transfer roller	RG5 4594-000CN	50,000	Can affect print quality and/or paper movement
Printer pickup roller assembly	RB2-3929-000CN	50,000	Look for glazing and/or cracks.
Printer separation pad	RF5-2832-000CN	50,000	Can affect paper movement
Printer separation sub-pads	RY7-5050-000CN	50,000	Can affect paper movement
Heating element (110 volts)	RG5-4589-000CN	50,000	Can affect paper quality and/or paper movement
Heating element (220 volts)	RG5-4890-000CN	50,000	Can affect paper quality and/or paper movement
Pressure roller	RF5-2823-000CN	50,000	Look for marks on pressure roller or upper Teflon sleeve.

### Accessory ordering information

DESCRIPTION	ITEM	ORDER NUMBER	REMARKS
Printer memory	Dual in-line memory module (DIMM)		Available DIMMs:
		C4135A	4 MB
		C4136A	8 MB
		C4137A	16 MB
Cables and interface accessories	Parallel cables	8120-8668	2 Meter IEEE-1284 cable
		C2946A	3 Meter IEEE-1284 cable
	Copier/Scanner for the HP LaserJet 1100	C4221A	Attachable scanner exclusively for the HP LaserJet 1100 printer.

### Ordering consumables

The consumables and accessories listed in the above table may be ordered from Hewlett-Packard.

The phone numbers are:

- U.S.: (800) 538-8787
- Canada: (800) 387-3154 (Toronto: (516) 671-8383)
- United Kingdom: 0734-441212
- Germany: 0130-3322
- SMO (Support Material Organization)  
1-800-227-8164 (U.S. only)
- SME (Support Materials Europe)  
(49 7031) 142253



Contact a local HP Parts Coordinator for other local phone numbers.

Parts that have no reference designator or part number are not field replacement parts and cannot be ordered through SMO.

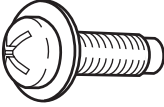

# Common hardware

## Common fasteners

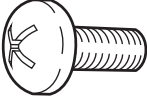
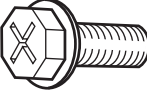
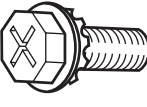
Example	Description
	Screw, machine, truss head
	Screw, star
	Screw, self-tapping
	Screw, hex-head
	Screw, hex-head, star

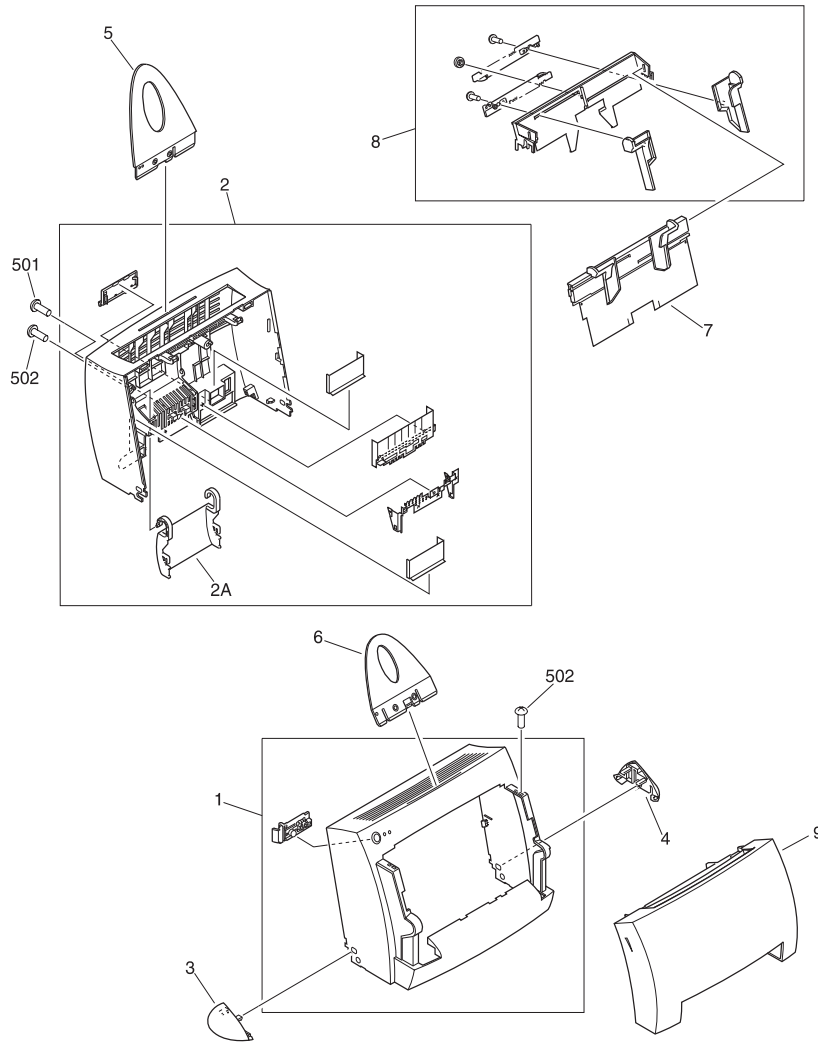

**Figure 6-1 External Covers, Panels, Etc.**

## External covers, panels, etc. parts list

KEY #.	PART #	QTY	DESCRIPTION
1	RF5-2827-000CN	1	COVER, FRONT
2	RF5-2828-000CN	1	COVER, REAR
2A	RB2-4014-000CN	1	MEMORY DOOR
3	RB2-4018-000CN	1	POD, LEFT
4	RB2-4019-000CN	1	POD, RIGHT
5	RB2-4020-000CN	1	INPUT PAPER SUPPORT
6	RB2-4021-000CN	1	OUTPUT/SCANNER PAPER SUPPORT
7	RG5-4601-000CN	1	SINGLE SHEET BIN
8	RG5-4602-000CN	1	INPUT PAPER BIN
9	RG5-4604-000CN	1	PRINTER DOOR
501	XB2-7300-607CN	1	SCREW, M3X6
502	XB4-7401-007CN	4	SCREW, M4X10

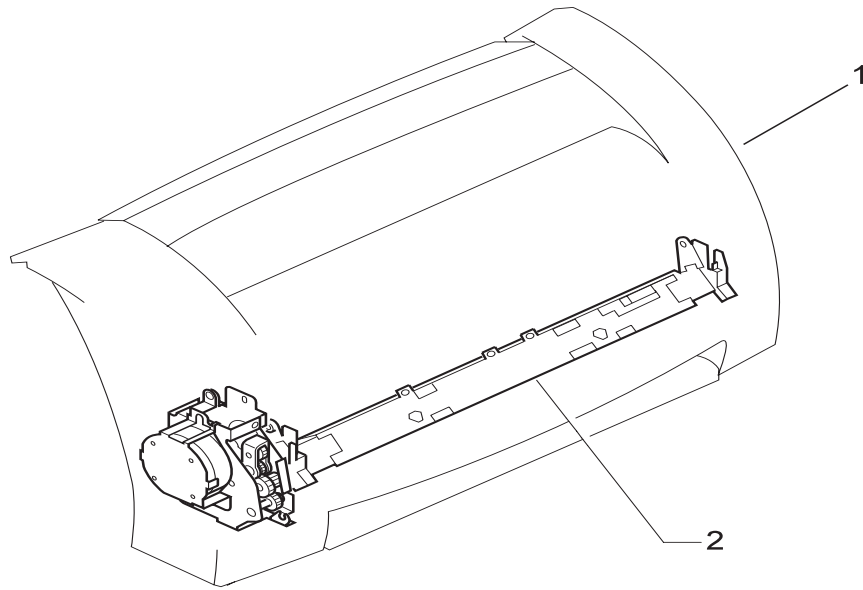

**Figure 6-2 Document Scanner**

**Document scanner parts list**

KEY #.	PART #	QTY	DESCRIPTION
1	R37-5000-000CN	1	SCANNER ASS'Y
2	RG5-4561-000CN	1	CONTACT IMAGE SENSOR

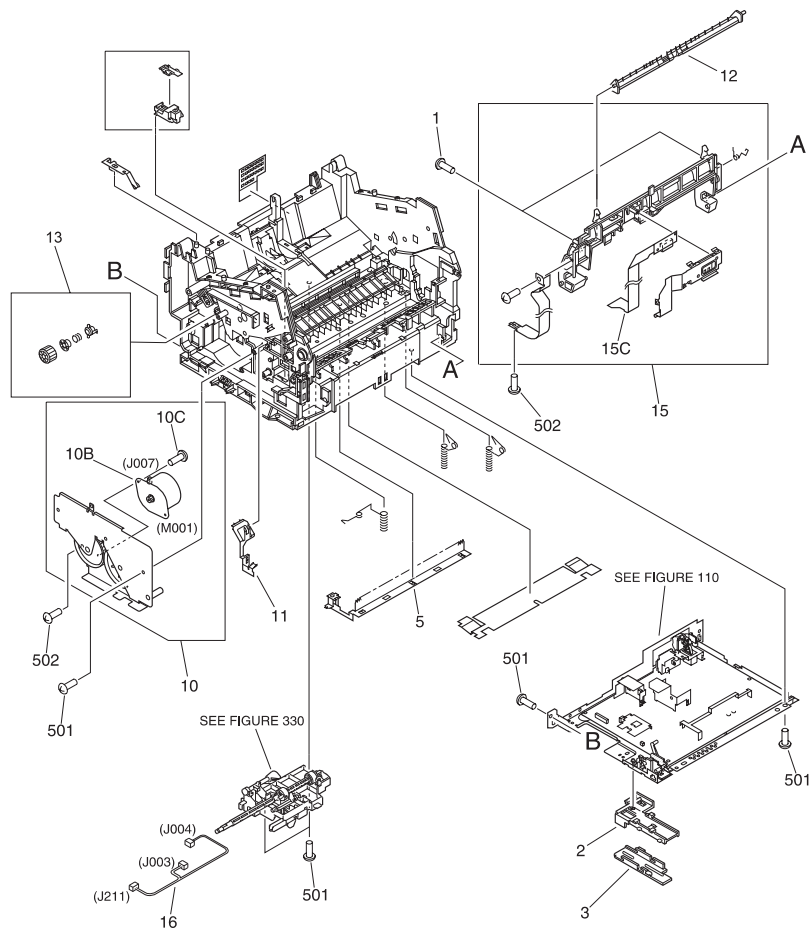

**Figure 6-3 Internal components, 1 of 4**

### Parts list, internal components 1 of 4

KEY #.	PART #	QTY	DESCRIPTION
1	XA9-0605-000CN	2	SCREW, M4X8
2	RB2-4017-000CN	1	HOLDER, FLAT CABLE
3	RB2-4030-000CN	1	COVER, HOLDER
5	RB2-3951-000CN	1	ELIMINATOR, STATIC CHARGE
10	RG5-4586-000CN	1	DRIVE ASS'Y
10B	RH7-1404-000CN	1	MAIN MOTOR
10C	XB6-7300-609CN	2	SCREW, M3X6
11	RB2-3959-000CN	1	SPRING, LEAF, LEFT
12	RB2-4006-000CN	1	GUIDE, FACE DOWN DELIVERY
13	RY7-5051-000CN	1	CLUTCH KIT
15	RG5-4653-000CN	1	CONNECTOR HOLDER ASS'Y
15C	RH2-5379-000CN	1	FLAT CABLE
16	RG5-4617-000CN	1	SENSOR CABLE (J211, J003, J004)
501	XB4-7401-007CN	8	SCREW, TAPPING, PAN HEAD, M4X10
502	XB2-7300-607CN	3	SCREW, W/WASHER, M3X6

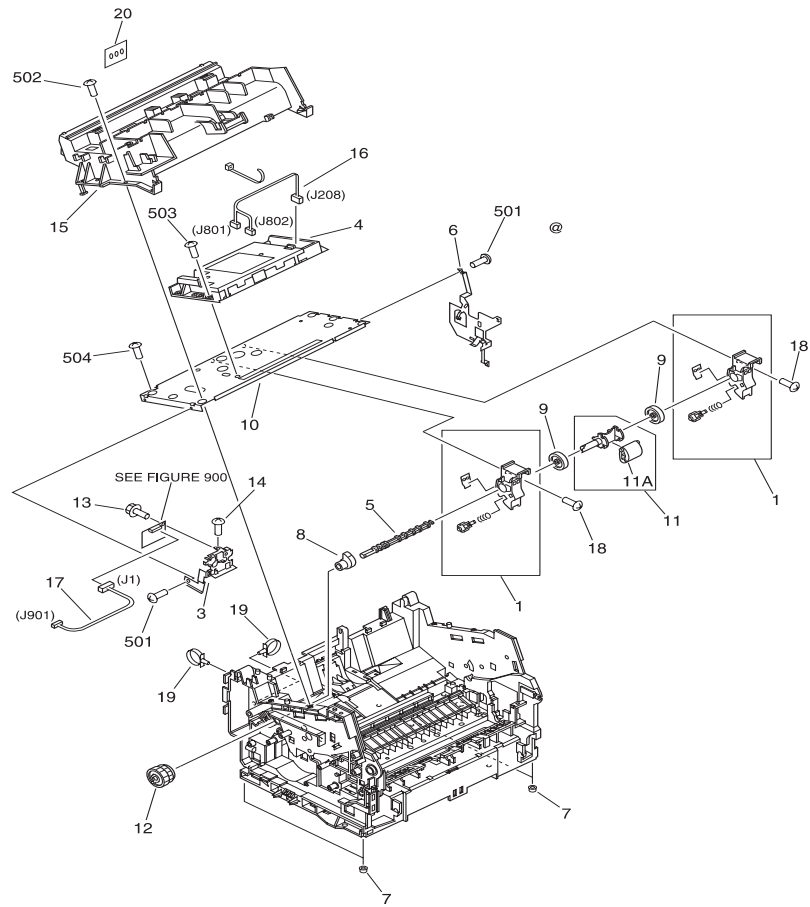
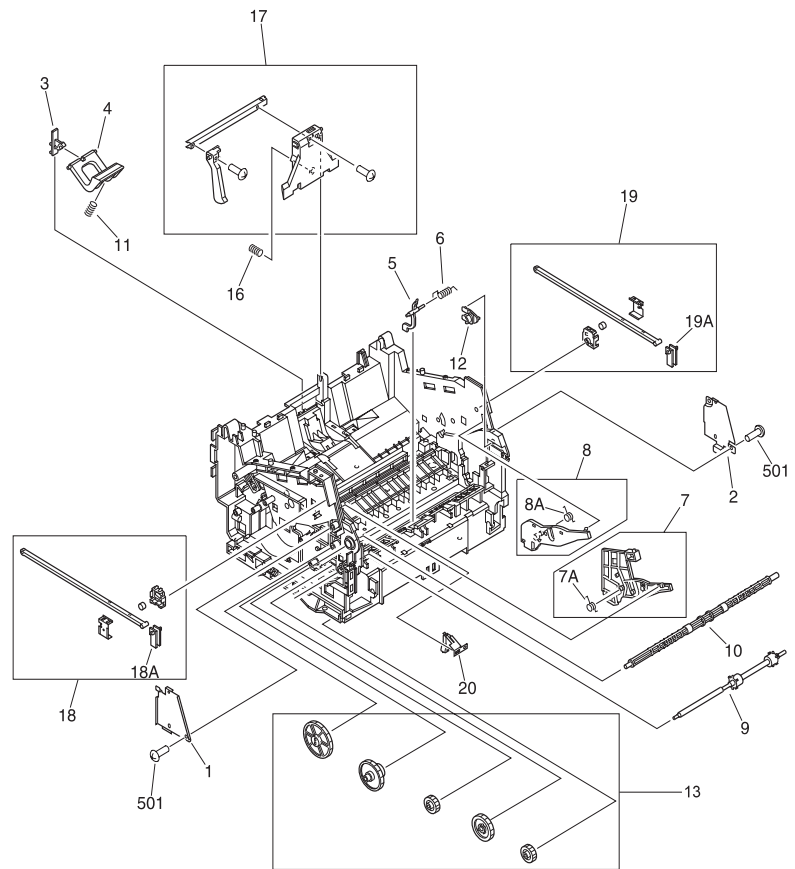

**Figure 6-4 Internal components, 2 of 4**

## Parts list, internal components 2 of 4

KEY #.	PART #	Q'TY	DESCRIPTION
1	RG5-4584-000CN	2	ROLLER HOLDER ASS'Y
3	RB2-4001-000CN	1	MOUNT, DISPLAY PCB
4	RG5-4570-000CN	1	LASER/SCANNER ASS'Y
5	RB2-3943-000CN	1	SHAFT
6	RB2-3944-000CN	1	SPRING, LEAF
7	RB2-3945-000CN	4	FOOT
8	RB2-3949-000CN	1	CAM
9	RB2-3931-000CN	2	ROLLER
10	RB2-3932-000CN	1	PLATE, SCANNER
11	RB2-3930-000CN	1	ROLLER SHAFT
11A	RB2-4026-000CN	1	ROLLER, PAPER PICK-UP
12	RG5-4585-000CN	1	GEAR ASS'Y
13	XA9-0686-000CN	1	SCREW, M3X6
14	XA9-0605-000CN	1	SCREW, M4X8
15	RB2-3999-000CN	1	DUCT, 2
16	RG5-4616-000CN	1	SCANNER CABLE -(J208, J801, J802)
17	RG5-4620-000CN	1	DISPLAY CABLE (J1, J901)
18	XA9-0267-000CN	2	SCREW, TP, M3X6
19	WT2-5041-000CN	2	TIE, CABLE
20	RG5-4608-000CN	1	DISPLAY PCB ASS'Y
501	XB2-7300-607 CN	3	SCREW, M3X6
502	XB4-7401-209 CN	2	SCREW, M4X12
503	XB6-7300-807 CN	4	SCREW, M3X8
504	XB4-7401-007 CN	2	SCREW, M4X10

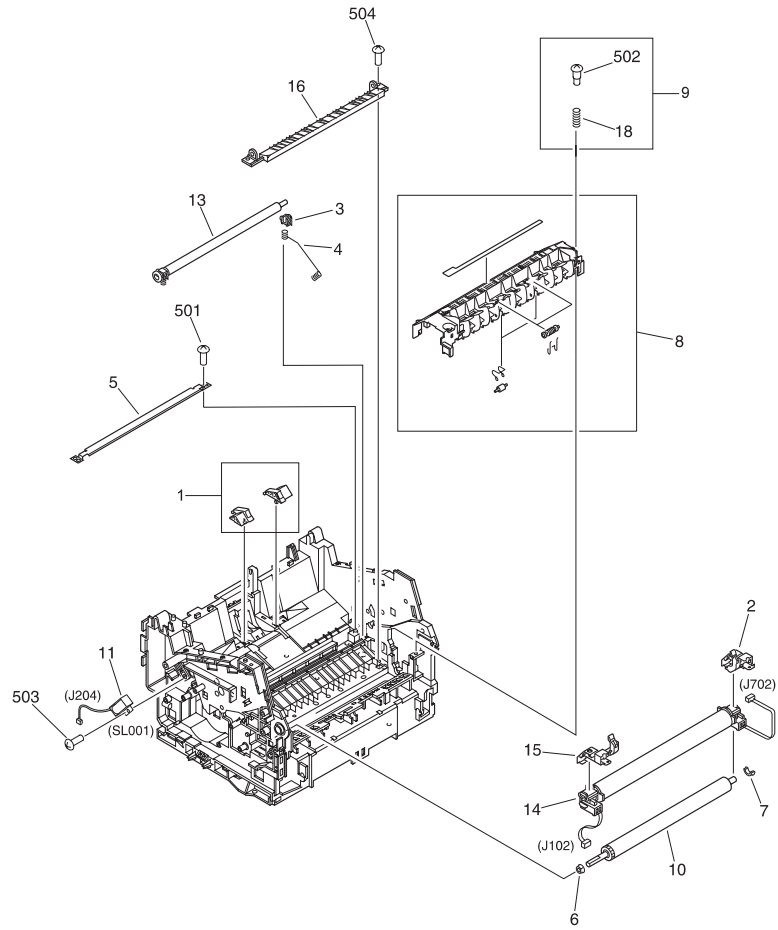



**Figure 6-5 Internal components, 3of 4**

### Parts list, internal components 3 of 4

KEY #	PART #	QTY	DESCRIPTION
1	RB2-3941-000CN	1	GUIDE, ARM, LEFT
2	RB2-3942-000CN	1	GUIDE, ARM, RIGHT
3	RB2-3947-000CN	1	HOLDER, PAD
4	RF5-2832-000CN	1	ARM, PAD
5	RB2-3960-000CN	1	FLAG, SENSOR
6	RB2-3961-000CN	1	TORSION SPRING
7	RF5-2818-000CN	1	GUIDE, CARTRIDGE, LEFT
8	RF5-2819-000CN	1	GUIDE, CARTRIDGE, RIGHT
9	RF5-2822-000CN	1	ROLLER, FACE-UP
10	RF5-2830-000CN	1	ROLLER, FACE-DOWN
11	RS5-2502-000CN	1	SPRING, COMPRESSION
12	RB2-4016-000CN	1	STOP, SLIDE
13	RY7-5049-000CN	1	GEAR KIT
16	RS6-2122-000CN	1	SPRING, COMPRESSION
17	RG5-4582-000CN	1	PAPER GUIDE PLATE ASS'Y
18	RG5-4587-000CN	1	ARM HOLDER ASS'Y LEFT
18A	RB2-4034-000CN	1	MOUNT, ARM
19	RG5-4588-000CN	1	ARM HOLDER ASS'Y RIGHT
19A	RB2-4034-000CN	1	MOUNT, ARM
20	RB2-4219-000CN	1	PLATE, GROUNDING
501	XB4-7401-007CN	3	SCREW, TAPPING, PAN HEAD, M4X10



**Figure 6-6 Internal components, 4 of 4**

### Parts list, internal components 4 of 4

KEY #	PART #	QTY	DESCRIPTION
1	RY7-5050-000CN	1	SUBPAD KIT
2	RG5-4592-000CN	1	FIXING PRESSURE ASS'Y, RIGHT
3	RB2-3939-000CN	1	BUSHING, RIGHT
4	RB2-3940-000CN	1	SPRING, COMPRESSION
5	RB2-3950-000CN	1	GUIDE, TRANSFER
6	RB2-3956-000CN	1	BUSHING, LEFT
7	RB2-3957-000CN	1	BUSHING, RIGHT
8	RG5-4593-000CN	1	DELIVERY ASS'Y
9	PENDING	1	DEVELOPER FASTENER KIT
10	RF5-2823-000CN	1	ROLLER, PRESSURE
11	RH7-5227-000CN	1	SOLENOID -(SL001, J204)
13	RG5-4594-000CN	1	TRANSFER ASS'Y
14	RG5-4589-000CN	1	FIXING FILM ASS'Y - 100-127V,( J102, J702)
14	RG5-4590-000CN	1	FIXING FILM ASS'Y - 220-240V
15	RG5-4591-000CN	1	FIXING PRESSURE ASS'Y, LEFT
16	RB2-3958-000CN	1	GUIDE, FIXING
18	RS6-2124-000CN	1	COMPRESSION SPRING
501	XB4-7400-805	2	SCREW, M4X8
502	XB6-7302-009	2	SCREW, M3X20
503	XB4-7401-007	1	SCREW, M4X10
504	XB4-7401-209	2	SCREW, M4X12
	CK-8006		PRESSURE ROLLER GREASE

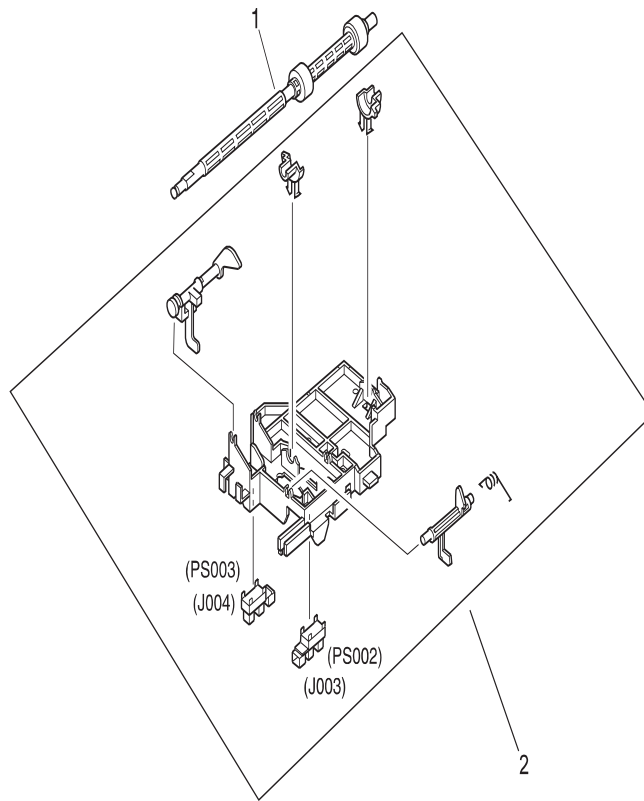

**Figure 6-7 Feeder assembly**

## Feeder assembly parts list

KEY #	PART #	QTY	DESCRIPTION
1	RB2-3912-000CN	1	FEED ROLLER
2	RG5-4581-000CN	1	FEEDER ASS'Y

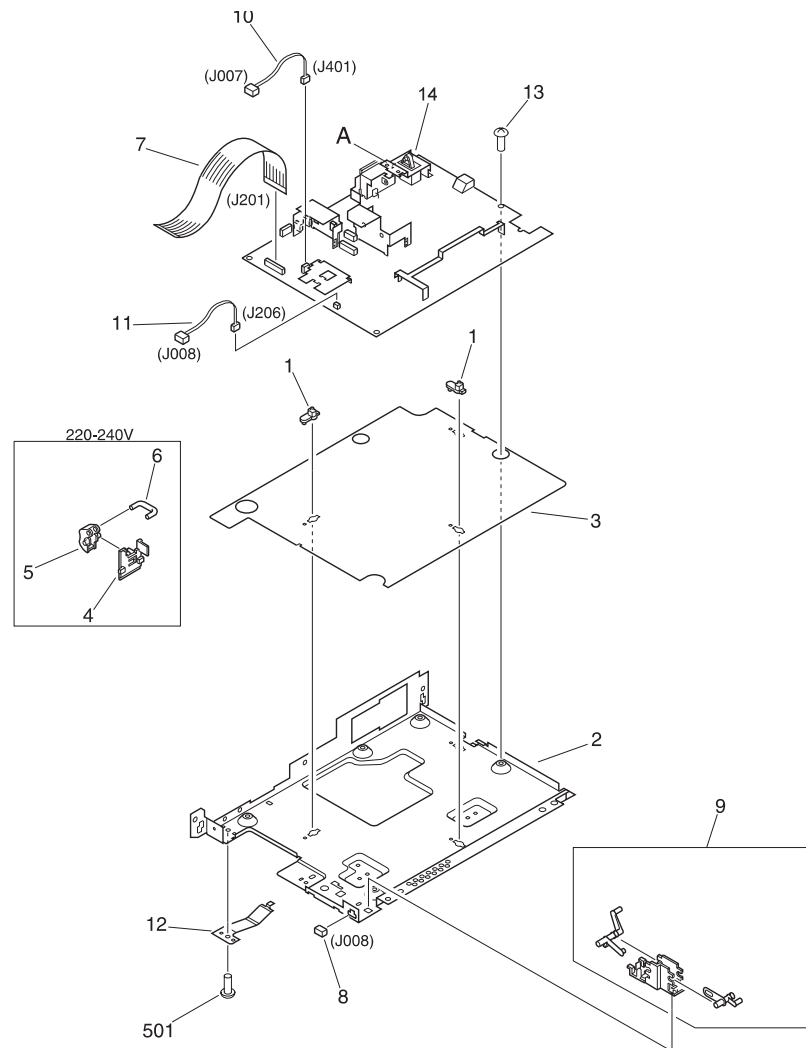
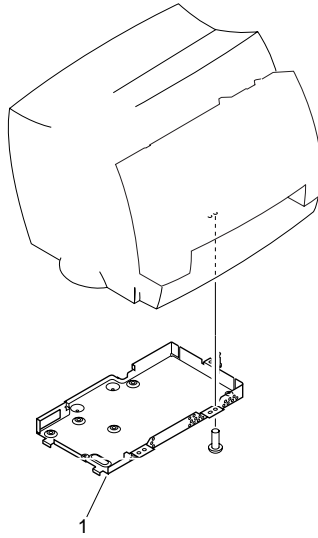

**Figure 6-8 Engine controller assembly**

## Engine controller assembly parts list

KEY #	PART #	Q'TY	DESCRIPTION
1	RB1-7303-000CN	3	SPACER, PCB
2	RB2-3984-000CN	1	CASE, PRINTER CONTROLLER
3	RB2-3985-000CN	1	SHEET, INSULATING
4	RB2-3986-000CN	1	HOLDER, POWER SWITCH LEVER
5	RB2-3987-000CN	1	LEVER, POWER SWITCH
6	RB2-3988-000CN	1	ROD, SWITCH
7	RH2-5381-000CN	1	FLAT CABLE, (J201)
8	VS1-5057-002 CN	1	CONNECTOR, 2P , (J008)
9	RG5-4599-000CN	1	DOOR SENSOR ASS'Y
10	RG5-4618-000CN	1	MOTOR CABLE, (J007, J401)
11	RG5-4619-000CN	1	THERMISTOR CABLE, (J008, J206)
12	RB2-4049-000CN	1	PLATE, GROUNDING
13	XA9-1016-000CN	6	SCREW M3X6
14	RG5-4605-000CN	1	ECU PCB ASS'Y
14	RG5-4606-000CN	1	ECU PCB ASS'Y
501	XB2-7300-607 CN	1	SCREW, M3X6





**Figure 6-9 Formatter pan**

**Formatter pan parts list**

<b>KEY #</b>	<b>PART #</b>	<b>Q'TY</b>	<b>DESCRIPTION</b>
1	RB2-3992-000CN	1	FORMATTER PLATE
2	C4146-67901	1	FORMATTER
3	0515-2672	7	FORMATTER SCREWS

## Parts list sorted by part number

Part Number	Qty	Description	Table #	Key #
0515-2672	7	FORMATTER SCREWS	8	3
C4146-67901	1	FORMATTER	8	2
CK-8006		PRESSURE ROLLER GREASE	5	
PENDING	1	DEVELOPER FASTENER KIT	5	9
R56-2124-000CN	1	COMPRESSION SPRING	5	18
RB1-7303-000CN	3	SPACER, PCB	7	1
RB2-3912-000CN	1	FEED ROLLER	6	1
RB2-3930-000CN	1	ROLLER SHAFT	3	11
RB2-3931-000CN	2	ROLLER	3	9
RB2-3932-000CN	1	PLATE, SCANNER	3	10
RB2-3939-000CN	1	BUSHING, RIGHT	5	3
RB2-3940-000CN	1	SPRING, COMPRESSION	5	4
RB2-3941-000CN	1	GUIDE, ARM, LEFT	4	1
RB2-3942-000CN	1	GUIDE, ARM, RIGHT	4	2
RB2-3943-000CN	1	SHAFT	3	5
RB2-3944-000CN	1	SPRING, LEAF	3	6
RB2-3945-000CN	4	FOOT	3	7
RB2-3947-000CN	1	HOLDER, PAD	4	3
RB2-3949-000CN	1	CAM	3	8
RB2-3950-000CN	1	GUIDE, TRANSFER	5	5
RB2-3951-000CN	1	ELIMINATOR, STATIC CHARGE	2	5
RB2-3956-000CN	1	BUSHING, LEFT	5	6
RB2-3957-000CN	1	BUSHING, RIGHT	5	7
RB2-3958-000CN	1	GUIDE, FIXING	5	16
RB2-3959-000CN	1	SPRING, LEAF, LEFT	2	11
RB2-3960-000CN	1	FLAG, SENSOR	4	5
RB2-3961-000CN	1	TORSION SPRING	4	6
RB2-3984-000CN	1	CASE, PRINTER CONTROLLER	7	2
RB2-3985-000CN	1	SHEET, INSULATING	7	3
RB2-3986-000CN	1	HOLDER, POWER SWITCH LEVER	7	4
RB2-3987-000CN	1	LEVER, POWER SWITCH	7	5
RB2-3988-000CN	1	ROD, SWITCH	7	6
RB2-3992-000CN	1	FORMATTER PLATE	8	
RB2-3999-000CN	1	DUCT, 2	3	15
RB2-4001-000CN	1	MOUNT, DISPLAY PCB	3	3
RB2-4006-000CN	1	GUIDE, FACE DOWN DELIVERY	2	12
RB2-4014-000CN	1	MEMORY DOOR	1	2A
RB2-4016-000CN	1	STOP, SLIDE	4	12
RB2-4017-000CN	1	HOLDER, FLAT CABLE	2	2
RB2-4018-000CN	1	POD, LEFT	1	3
RB2-4019-000CN	1	POD, RIGHT	1	4
RB2-4020-000CN	1	INPUT PAPER SUPPORT	1	5

Part Number	Qty	Description	Table #	Key #
RB2-4021-000CN	1	OUTPUT/SCANNER PAPER SUPPORT	1	6
RB2-4026-000CN	1	ROLLER, PAPER PICK-UP	3	11A
RB2-4030-000CN	1	COVER, HOLDER	2	3
RB2-4034-000CN	1	MOUNT, ARM	4	18A
RB2-4034-000CN	1	MOUNT, ARM	4	19A
RB2-4049-000CN	1	PLATE, GROUNDING	7	12
RB2-4219-000CN	1	PLATE, GROUNDING	4	20
RF5-2818-000CN	1	GUIDE, CARTRIDGE, LEFT	4	7
RF5-2819-000CN	1	GUIDE, CARTRIDGE, RIGHT	4	8
RF5-2822-000CN	1	ROLLER, FACE-UP	4	9
RF5-2823-000CN	1	ROLLER, PRESSURE	5	10
RF5-2827-000CN	1	COVER, FRONT	1	1
RF5-2828-000CN	1	COVER, REAR	1	2
RF5-2830-000CN	1	ROLLER, FACE-DOWN	4	10
RF5-2832-000CN	1	ARM, PAD	4	4
RG5-4570-000CN	1	LASER/SCANNER ASS'Y	3	4
RG5-4581-000CN	1	FEEDER ASS'Y	6	2
RG5-4582-000CN	1	PAPER GUIDE PLATE ASS'Y	4	17
RG5-4584-000CN	2	ROLLER HOLDER ASS'Y	3	1
RG5-4585-000CN	1	GEAR ASS'Y	3	12
RG5-4586-000CN	1	DRIVE ASS'Y	2	10
RG5-4587-000CN	1	ARM HOLDER ASS'Y LEFT	4	18
RG5-4588-000CN	1	ARM HOLDER ASS'Y RIGHT	4	19
RG5-4589-000CN	1	FIXING FILM ASS'Y - 100-127V,( J102,J702)	5	14
RG5-4590-000CN	1	FIXING FILM ASS'Y - 220-240V	5	14
RG5-4591-000CN	1	FIXING PRESSURE ASS'Y, LEFT	5	15
RG5-4592-000CN	1	FIXING PRESSURE ASS'Y, RIGHT	5	2
RG5-4593-000CN	1	DELIVERY ASS'Y	5	8
RG5-4594-000CN	1	TRANSFER ASS'Y	5	13
RG5-4599-000CN	1	DOOR SENSOR ASS'Y	7	9
RG5-4601-000CN	1	SINGLE SHEET BIN	1	7
RG5-4602-000CN	1	INPUT PAPER BIN	1	8
RG5-4604-000CN	1	PRINTER DOOR	1	9
RG5-4605-000CN	1	ECU PCB ASS'Y	7	14
RG5-4606-000CN	1	ECU PCB ASS'Y	7	14
RG5-4608-000CN	1	DISPLAY PCB ASS'Y	3	20
RG5-4616-000CN	1	SCANNER CABLE -(J208, J801, J802)	3	16
RG5-4617-000CN	1	SENSOR CABLE (J211, J003, J004)	2	16
RG5-4618-000CN	1	MOTOR CABLE, (J007, J401)	7	10
RG5-4619-000CN	1	THERMISTOR CABLE, (J008, J206)	7	11
RG5-4620-000CN	1	DISPLAY CABLE (J1, J901)	3	17
RG5-4653-000CN	1	CONNECTOR HOLDER ASS'Y	2	15
RH2-5379-000CN	1	FLAT CABLE	2	15C
RH2-5381-000CN	1	FLAT CABLE, (J201)	7	7
RH7-1404-000CN	1	MAIN MOTOR	2	10B

Part Number	Qty	Description	Table #	Key #
RH7-5227-000CN	1	SOLENOID -(SL001, J204)	5	11
RS5-2502-000CN	1	SPRING, COMPRESSION	4	11
RS6-2122-000CN	1	SPRING, COMPRESSION	4	16
RY7-5049-000CN	1	GEAR KIT	4	13
RY7-5050-000CN	1	SUBPAD KIT	5	1
RY7-5051-000CN	1	CLUTCH KIT	2	13
VS1-5057-002 CN	1	CONNECTOR, 2P , (J008)	7	8
WT2-5041-000CN	2	TIE, CABLE	3	19
XA9-0267-000CN	2	SCREW, TP, M3X6	3	18
XA9-0605-000CN	2	SCREW, M4X8	2	1
XA9-0605-000CN	1	SCREW, M4X8	3	14
XA9-0686-000CN	1	SCREW, M3X6	3	13
XA9-1016-000CN	6	SCREW M3X6	7	13
XB2-7300-607 CN	3	SCREW, M3X6	3	501
XB2-7300-607 CN	1	SCREW, M3X6	7	501
XB2-7300-607CN	1	SCREW, M3X6	1	501
XB2-7300-607CN	3	SCREW, W/WASHER, M3X6	2	502
XB4-7400-805	2	SCREW, M4X8	5	501
XB4-7401-007	1	SCREW, M4X10	5	503
XB4-7401-007 CN	2	SCREW, M4X10	3	504
XB4-7401-007CN	4	SCREW, M4X10	1	502
XB4-7401-007CN	8	SCREW,TAPPING,PAN HEAD,M4X10	2	501
XB4-7401-007CN	3	SCREW,TAPPING,PAN HEAD,M4X10	4	501
XB4-7401-209	2	SCREW, M4X12	5	504
XB4-7401-209 CN	2	SCREW,M4X12	3	502
XB6-7300-609CN	2	SCREW, M3X6	2	10C
XB6-7300-807 CN	4	SCREW, M3X8	3	503
XB6-7302-009	2	SCREW, M3X20	5	502

## Parts list sorted by part name

Part name	Qty	Part Number	Table #	Key #
ARM HOLDER ASS'Y LEFT	1	RG5-4587-000CN	4	18
ARM HOLDER ASS'Y RIGHT	1	RG5-4588-000CN	4	19
ARM, PAD	1	RF5-2832-000CN	4	4
BUSHING, LEFT	1	RB2-3956-000CN	5	6
BUSHING, RIGHT	1	RB2-3939-000CN	5	3
BUSHING, RIGHT	1	RB2-3957-000CN	5	7
CAM	1	RB2-3949-000CN	3	8
CASE, PRINTER CONTROLLER	1	RB2-3984-000CN	7	2
CLUTCH KIT	1	RY7-5051-000CN	2	13
COMPRESSION SPRING	1	R56-2124-000CN	5	18
CONNECTOR HOLDER ASS'Y	1	RG5-4653-000CN	2	15
CONNECTOR, 2P , (J008)	1	VS1-5057-002 CN	7	8
COVER, FRONT	1	RF5-2827-000CN	1	1
COVER, HOLDER	1	RB2-4030-000CN	2	3
COVER, REAR	1	RF5-2828-000CN	1	2
DELIVERY ASS'Y	1	RG5-4593-000CN	5	8
DEVELOPER FASTENER KIT	1	PENDING	5	9
DISPLAY CABLE (J1, J901)	1	RG5-4620-000CN	3	17
DISPLAY PCB ASS'Y	1	RG5-4608-000CN	3	20
DOOR SENSOR ASS'Y	1	RG5-4599-000CN	7	9
DRIVE ASS'Y	1	RG5-4586-000CN	2	10
DUCT, 2	1	RB2-3999-000CN	3	15
ELIMINATOR, STATIC CHARGE	1	RB2-3951-000CN	2	5
FEED ROLLER	1	RB2-3912-000CN	6	1
FEEDER ASS'Y	1	RG5-4581-000CN	6	2
FIXING FILM ASS'Y - 100-127V,( J102,J702)	1	RG5-4589-000CN	5	14
FIXING FILM ASS'Y - 220-240V	1	RG5-4590-000CN	5	14
FIXING PRESSURE ASS'Y, LEFT	1	RG5-4591-000CN	5	15
FIXING PRESSURE ASS'Y, RIGHT	1	RG5-4592-000CN	5	2
FLAG, SENSOR	1	RB2-3960-000CN	4	5
FLAT CABLE	1	RH2-5379-000CN	2	15C
FLAT CABLE, (J201)	1	RH2-5381-000CN	7	7
FOOT	4	RB2-3945-000CN	3	7
FORMATTER	1	C4146-67901	8	2
FORMATTER PLATE	1	RB2-3992-000CN	8	1
FORMATTER SCREWS	7	0515-2672	8	3
GEAR ASS'Y	1	RG5-4585-000CN	3	12
GEAR KIT	1	RY7-5049-000CN	4	13
GUIDE, ARM, LEFT	1	RB2-3941-000CN	4	1
GUIDE, ARM, RIGHT	1	RB2-3942-000CN	4	2
GUIDE, CARTRIDGE, LEFT	1	RF5-2818-000CN	4	7
GUIDE, CARTRIDGE, RIGHT	1	RF5-2819-000CN	4	8

Part name	Qty	Part Number	Table #	Key #
GUIDE, FACE DOWN DELIVERY	1	RB2-4006-000CN	2	12
GUIDE, FIXING	1	RB2-3958-000CN	5	16
GUIDE, TRANSFER	1	RB2-3950-000CN	5	5
HOLDER, FLAT CABLE	1	RB2-4017-000CN	2	2
HOLDER, PAD	1	RB2-3947-000CN	4	3
HOLDER, POWER SWITCH LEVER	1	RB2-3986-000CN	7	4
INPUT PAPER BIN	1	RG5-4602-000CN	1	8
INPUT PAPER SUPPORT	1	RB2-4020-000CN	1	5
LASER/SCANNER ASS'Y	1	RG5-4570-000CN	3	4
LEVER, POWER SWITCH	1	RB2-3987-000CN	7	5
MAIN MOTOR	1	RH7-1404-000CN	2	10B
MEMORY DOOR	1	RB2-4014-000CN	1	2A
MOTOR CABLE, (J007, J401)	1	RG5-4618-000CN	7	10
MOUNT, ARM	1	RB2-4034-000CN	4	18A
MOUNT, ARM	1	RB2-4034-000CN	4	19A
MOUNT, DISPLAY PCB	1	RB2-4001-000CN	3	3
OUTPUT/SCANNER PAPER SUPPORT	1	RB2-4021-000CN	1	6
PAPER GUIDE PLATE ASS'Y	1	RG5-4582-000CN	4	17
PLATE, GROUNDING	1	RB2-4049-000CN	7	12
PLATE, GROUNDING	1	RB2-4219-000CN	4	20
PLATE, SCANNER	1	RB2-3932-000CN	3	10
POD, LEFT	1	RB2-4018-000CN	1	3
POD, RIGHT	1	RB2-4019-000CN	1	4
PRESSURE ROLLER GREASE		CK-8006	5	
ECU PCB ASS'Y	1	RG5-4605-000CN	7	14
ECU PCB ASS'Y	1	RG5-4606-000CN	7	14
PRINTER DOOR	1	RG5-4604-000CN	1	9
ROD, SWITCH	1	RB2-3988-000CN	7	6
ROLLER	2	RB2-3931-000CN	3	9
ROLLER HOLDER ASS'Y	2	RG5-4584-000CN	3	1
ROLLER SHAFT	1	RB2-3930-000CN	3	11
ROLLER, FACE-DOWN	1	RF5-2830-000CN	4	10
ROLLER, FACE-UP	1	RF5-2822-000CN	4	9
ROLLER, PAPER PICK-UP	1	RB2-4026-000CN	3	11A
ROLLER, PRESSURE	1	RF5-2823-000CN	5	10
SCANNER CABLE -(J208, J801, J802)	1	RG5-4616-000CN	3	16
SCREW M3X6	6	XA9-1016-000CN	7	13
SCREW, M3X20	2	XB6-7302-009	5	502
SCREW, M3X6	1	XA9-0686-000CN	3	13
SCREW, M3X6	3	XB2-7300-607 CN	3	501
SCREW, M3X6	1	XB2-7300-607 CN	7	501
SCREW, M3X6	1	XB2-7300-607CN	1	501
SCREW, M3X6	2	XB6-7300-609CN	2	10C
SCREW, M3X8	4	XB6-7300-807 CN	3	503
SCREW, M4X10	1	XB4-7401-007	5	503

Part name	Qty	Part Number	Table #	Key #
SCREW, M4X10	2	XB4-7401-007 CN	3	504
SCREW, M4X10	4	XB4-7401-007CN	1	502
SCREW, M4X12	2	XB4-7401-209	5	504
SCREW, M4X8	2	XA9-0605-000CN	2	1
SCREW, M4X8	1	XA9-0605-000CN	3	14
SCREW, M4X8	2	XB4-7400-805	5	501
SCREW, TP, M3X6	2	XA9-0267-000CN	3	18
SCREW, W/WASHER, M3X6	3	XB2-7300-607CN	2	502
SCREW,M4X12	2	XB4-7401-209 CN	3	502
SCREW,TAPPING,PAN HEAD,M4X10	8	XB4-7401-007CN	2	501
SCREW,TAPPING,PAN HEAD,M4X10	3	XB4-7401-007CN	4	501
SENSOR CABLE (J211, J003, J004)	1	RG5-4617-000CN	2	16
SHAFT	1	RB2-3943-000CN	3	5
SHEET, INSULATING	1	RB2-3985-000CN	7	3
SINGLE SHEET BIN	1	RG5-4601-000CN	1	7
SOLENOID -(SL001, J204)	1	RH7-5227-000CN	5	11
SPACER, PCB	3	RB1-7303-000CN	7	1
SPRING, COMPRESSION	1	RB2-3940-000CN	5	4
SPRING, COMPRESSION	1	RS5-2502-000CN	4	11
SPRING, COMPRESSION	1	RS6-2122-000CN	4	16
SPRING, LEAF	1	RB2-3944-000CN	3	6
SPRING, LEAF, LEFT	1	RB2-3959-000CN	2	11
STOP, SLIDE	1	RB2-4016-000CN	4	12
SUBPAD KIT	1	RY7-5050-000CN	5	1
THERMISTOR CABLE, (J008, J206)	1	RG5-4619-000CN	7	11
TIE, CABLE	2	WT2-5041-000CN	3	19
TORSION SPRING	1	RB2-3961-000CN	4	6
TRANSFER ASS'Y	1	RG5-4594-000CN	5	13

- AC power distribution 42
- accessories and consumables
  - ordering 159
- adjusting registration 138
- assemblies
  - fusing 49
  - high-voltage connector 145
- assembly diagrams 156
  
- bidirectional
  - ECP interface 44
- black
  - dots on pages 124
  - dots on scanned images 129
  - pages 126
  - streaks on page 124
- blank
  - areas on page 126
  - bottom of page or graphic 127
  - pages 127
- bottom of page or graphic cut off 127
  
- cartridge sensor (SW101) 52
- characters partially printed 127
- charging the drum 48
- checking registration 138
- checks
  - drum rotation 141
  - half-self test 140
  - high-voltage power supply 144
- circuit



- driver 53
- circuitry
  - high-voltage 43
  - power 42
- Cleaning
  - printer ??– 135
  - printer paper path 135
- cleaning
  - photosensitive drum process 47
  - toner cartridge connection points 144
- components, internal
  - illustrations 165, 169, 173, 175, 177
- connection points for toner cartridge 144
- conserving toner 45
- consumables and accessories
  - ordering 159
- contact image sensor 53
- control panel
  - description 45
- control, paper motion 41
- crooked pages 132
- curled
  - pages 131
  - paper 145
- customer support
  - ordering parts 157
  - Support Materials Europe (SME) 157
  - Support Materials Organization (SMO) 157
- dark
  - faxes 122
  - scanned images 122

- date/time
  - toner cartridge expiration 121
- DC power distribution 42
- delivery roller
  - motion 145
- developing process 48
- diagrams
  - assembly 156
  - timing 56
- distribution of power 42
- document sensor (PS801) 52
- documents
  - fall out of feeder tray 134
- door open sensor (SW101) 52
- dots
  - on pages 124
  - on scanned images 129
- draft mode 45
- DRAM (dynamic random-access memory) 44
- driver
  - circuits 53
  - roller motion 145
- dropouts in characters 127
- drum rotation functional check 141
- drum, photosensitive
  - charging 48
  - cleaning process 47
  - troubleshooting 121
- dynamic random-access memory (DRAM) 44
  
- ECP interface 44
- ECU (engine controller unit)

- description 40
- loads 40
- edge of paper, not printing to 122
- electrophotographic process 140
- engine control function 39
- engine test 138
- engine test switch (SW201) 52
- Error messages
  - printer
    - light patterns 8, 23
- ESD (electrostatic discharge)
  - caution 59
  - mat 60
- exit rollers 49
- expiration date of toner cartridges 121
  
- faded print 123
- fasteners, common 161
- faxes
  - light or dark 122
- feed assembly drive rollers 49
- feed functions 39
- feeding problems 132, 133
- fixing
  - process 48
- formatter 44
- functional checks
  - drum rotation 141
- fuser
  - gear motion 145
  - roller motion 145
- fuses 42

- fusing
  - assembly 49
  - element 48
  
- graphic, bottom cut off 127
  
  
- half-self test 140
- hardware
  - common 161
- high-voltage
  - connector assembly 145
  - power distribution 43
  - power supply check 144
  
- image fixing process 48
- image formation
  - function 39
  - system 47
  - troubleshooting 121
- images
  - lines on page 124
  - too light or dark 122
- installing self-tapping screws 59
  
  
- kick plate
  - motion 49, 145
  
  
- LED (light-emitting diode) array 53
- light
  - faxes 122
  - printing 123
  - scanned images 122

- Light patterns
  - printer 8, 23
- light-emitting diode (LED) array 53
- lines
  - on scanned images 124
- memory
  - DRAM (dynamic random-access memory) 44
  - RAM (random-access memory) 44
- misaligned print 129
- missing bottom of page or graphic 127
- mode, draft 45
- monitoring paper motion 41
- motion control 41
- motor
  - description 41
  - rotation 145
- multiple pages feeding 132, 133
  
- optical system 53
- ordering
  - accessories and consumables 159
- overcurrent 42
- overview of processes 38
- overvoltage 42
  
- pads
  - separation 49
  - sub 49
- page
  - engine test 138
- pages

- blank print 127
- bottom cut off 127
- completely black 126
- crooked 132
- curled or wrinkled 131
- long stop feeding 131
- multiple feeding 132, 133
- skewed 129, 131
- paper
  - curl 145
  - feed problems 131
  - motion 49
  - not being picked up 145
  - not moving through path 145
  - not printing to edge 122
- paper exit sensor (PS201) 49, 51, 52
- paper jams 132, 133
- paper motion control 41
- paper out sensor (PS202) 51, 52
- paper path
  - check 145
- paper registration sensor (PS203) 49, 51, 52
- partially printed characters 127
- parts
  - lists 156
- path
  - scanner 53
- path, paper
  - check 145
- photosensitive drum
  - charging 48
  - cleaning process 47
  - troubleshooting 121

- phototransistor array 53
- pickup roller assembly
  - motion 145
- pickup/feed functions 39
- plates
  - kick 49, 145
- pliers required for servicing 60
- power
  - AC distribution 42
  - DC distribution 42
  - high-voltage distribution 43
  - shutoff switch 41
  - supply check 144
  - system description 40, 42
- primary charging 48
- print
  - misaligned 131
  - skewed 131
- print engine control system 41
- Printer
  - light patterns 8, 23
  - specifications 10–12
- printer
  - functions 39
  - isolating problems 138
  - laser/scanner functions 39
- printing
  - engine test page 138
  - faded 123
  - misaligned 129
  - to edge of paper 122
  - won't print 122
- product

- block diagram 39
- overview of processes 38
- protection, overcurrent 42
  
- RAM (random-access memory) 44
- random-access memory (RAM) 44
- recycling toner cartridges 35
- registration checking and adjusting 138
- rod lens array 53
- rollers
  - exit 49
  - feed assembly drive 49
  - motion 145
- rotation, drum 141
  
- scan
  - process 140
- scanned images
  - lines on page 124
  - too light or dark 122
- scanned text unclear 129
- scanner
  - path 53
  - system 53
- scattered toner on page 126
- screwdrivers required for servicing 60
- screws
  - common 161
  - installing 59
  - self-tapping 59
- self-tapping screws, installing 59
- sensors



- contact image 53
- document 52
- door open 52
- location and function 52
- paper exit 52
- paper exit (PS201) 49, 51
- paper out (PS202) 51, 52
- paper registration (PS203) 49, 51, 52
- toner cartridge 52
- separating process 48
- separation pads
  - description 49
- service and support
  - ordering parts 157
  - Support Materials Europe (SME) 157
  - Support Materials Organization (SMO) 157
- shutoff switch 41
- skewed
  - pages 131
  - print 129
- smears on page 124
- smudges on page 124
- solenoid 52
- solenoid assembly 145
- Specifications
  - printer 10– 12
- stains on page 124
- streaks
  - on pages 124
  - on scanned images 129
- stripes on page, white 123
- subassembly diagrams 156
- subpads

- description 49
- summary of processes 38
- support and service
  - ordering parts 157
- Support Materials Europe (SME) 157
- switches
  - engine test (SW201) 52
  - location and function 52
  - power shutoff 41
  
- test
  - engine switch (SW201) 52
  - page for engine 138
- tests
  - engine 138
  - half-self 140
- text, scanned, unclear 129
- timing diagram 56
- toner
  - draft mode for conserving 45
  - scattered on page 126
- toner cartridge 35
  - recycling 35
  - refilled 35
- toner cartridges
  - checking 121
  - checking and cleaning connection points 144
  - description 47
  - expiration date 121
  - photosensitive drum 121
  - sensor 52
  - weight when full and empty 121

- tools
  - servicing 60
  - troubleshooting 145
- transfer process 140
- transfer roller
  - motion 145
- trays
  - documents fall out 134
- Troubleshooting
  - printer
    - light patterns 8, 23
- troubleshooting
  - drum rotation 141
  - image formation 121
  - paper feed problems 131
  - process malfunctions 140
  - tools 145
- video controller 53
- void areas on page 126
- voltage
  - distribution 42
  - high 43
  - over 42
  - power supply check 144
  - protection 42
- warranty statement 36
- weight
  - toner cartridge when full and empty 121
- white
  - areas on page 126

stripes on page 123

wrinkled pages 131